



Enhancing our communities



Douglas Landing Subdivision

PRELIMINARY STORMWATER MANAGEMENT REPORT

Douglas Landing Developments

Document Control

File:

522650

Date:



January
13, 2025

Prepared by:

Tatham Engineering Limited
5335 Canotek Road, Unit 100
Ottawa, Ontario K1J 9L4
T 613-747-3636
tathameng.com

Prepared for:

Douglas Landing Developments
1 Forillon Crescent
Kanata, ON K2M 2W5

Authored by:	Reviewed by:
	
<p>David Viktor Fendler Technologist</p>	<p>Jeremy Ash, B.Sc.Eng., P.Eng. Director, Manager - Ottawa Office</p>

Disclaimer	Copyright
<p>The information contained in this document is solely for the use of the Client identified on the cover sheet for the purpose for which it has been prepared and Tatham Engineering Limited undertakes no duty to or accepts any responsibility to any third party who may rely upon this document.</p>	<p>This document may not be used for any purpose other than that provided in the contract between the Owner/Client and the Engineer nor may any section or element of this document be removed, reproduced, electronically stored or transmitted in any form without the express written consent of Tatham Engineering Limited.</p>

Issue	Date	Description
0	December 13, 2024	Draft Report
1	January 13, 2025	Final Report

Document Contents

1	Introduction	1
1.1	Site Description	1
1.2	Proposed Development.....	1
1.3	Guidelines and Background Reports.....	2
2	Geotechnical and Hydrogeological Investigations	3
2.1	Geotechnical Investigation	3
2.2	Hydrogeological Investigation	3
3	Internal Roadway and Transportation.....	5
4	Grading	6
5	Stormwater Management	7
5.1	Existing Site Drainage Conditions.....	7
5.2	External Drainage Conditions.....	8
5.3	Existing Condition Hydrologic Analysis.....	8
5.4	Stormwater Management Alternatives	10
5.5	Stormwater Management Plan.....	11
5.6	Stormwater Conveyance.....	18
6	Siltation and Erosion Control.....	19
7	Summary.....	20

Tables

Table 1:	Existing Condition Peak Flow Summary – Outlet 1	9
Table 2:	Existing Condition Peak Flow Summary – Outlet 2	10
Table 3:	Proposed Condition Peak Flow Summary – Outlet 1.....	14
Table 4:	Proposed Condition Peak Flow Summary – Outlet 2.....	15



Figures

Figure 1: DP-1: Existing Condition Drainage Plan..... 21
Figure 2: DP-2: Proposed Condition Drainage Plan..... 22
Figure 3: EXT-1: External Drainage Plan 23

Drawings

- Douglas Landing Draft Plan of Subdivision
- SG-1 - Preliminary Site Grading Plan
- SWM-1 - Preliminary Stormwater Management Plan

Appendices

- Appendix A: Stormwater Management Calculations



1 Introduction

Tatham Engineering Limited was retained by Douglas Landing Developments to prepare a preliminary stormwater management (SWM) report in support of a proposed 23-lot Draft Plan of Subdivision located at the west limits of Douglas Side Road in the Township of Beckwith. The subject site is legally described as Part of Lot 25, Concession 12, Township of Beckwith, County of Lanark.

The purpose of this report is to demonstrate the feasibility of the proposed development as it relates to stormwater management (SWM) in context with the local municipal, provincial and conservation authority SWM design guidelines and criteria.

1.1 SITE DESCRIPTION

The site consists of approximately 22.2 ha of land that is bounded by the recently developed Ridgemont Subdivision to the east, active agricultural lands to the north and west, and densely forested and wetland areas to the south.

The site location is illustrated on the key plan of the drawings attached at the back of this report.

1.2 PROPOSED DEVELOPMENT

The proposed development consists of approximately 22.2 ha of land, on which 23 privately serviced estate residential lots (varying in size from 0.40 ha to 1.44 ha) and approximately 1095 m of paved internal road having a rural cross section, are proposed for development.

Potable water and sewage treatment and disposal will be provided with individual groundwater wells and septic systems on each lot. A hydrogeological assessment report was prepared by Pinchin dated January 13, 2025 and provides further detail regarding the feasibility of individual private wells and septic systems on each lot.

The future condition land cover will be a combination of trees, grass and impervious areas (buildings, driveways, and roadways) as well as natural forested and wetland areas, which will remain undisturbed.

The Draft Plan of Subdivision was prepared by Fairhall Moffatt & Woodland Limited dated January 13, 2025 and is included at the back of this report.



1.3 GUIDELINES AND BACKGROUND REPORTS

This report was prepared recognizing municipal, provincial and conservation authority guidelines on water resources and the environment, including the following publications:

- Ministry of Municipal Affairs and Housing Provincial Planning Statement (2024);
- Low Impact Development Stormwater Management Planning and Design Guide (CVC and TRCA, 2010);
- The Ministry of Environment (MOE) Stormwater Management Practices Planning and Design Manual (2003); and
- MTO Drainage Management Manual (Ministry of Transportation, 1997).

The following background reports pertaining to the site have also been referenced in the preparation of this report:

- Douglas Side Road Fish Habitat Assessment - Lot 25, Concession 12, Beckwith Township, Lanark County (Geofirma Engineering Limited, June 12, 2017);
- Geotechnical Investigation - Proposed Residential Development (Pinchin Limited, November 26, 2024); and
- Hydrogeological Investigation - Proposed Residential Development (Pinchin Limited, January 13, 2025).



2 Geotechnical and Hydrogeological Investigations

2.1 GEOTECHNICAL INVESTIGATION

A Geotechnical Investigation within the site was completed by Pinchin Ltd. on September 15, 2022, and is documented in their report dated November 26, 2024.

A total of ten (10) sampled boreholes were advanced with the use of a CME55 track-mounted drill rig to practical refusal.

The subsurface conditions encountered in the boreholes revealed 50 mm to 150 mm of surficial organics underlain with glacial till. The glacial till material ranged in soil matrix from silty sand containing some gravel and some clay, to silty sandy gravel containing trace clay. Refusal to drill advancement was encountered on the probable bedrock surface in all boreholes at depths ranging from approximately 0.3 to 0.6 metres below the existing ground level (mbgl). Groundwater seepage was not observed within the open boreholes upon completion of drilling albeit seasonal variations in the groundwater elevation should be expected, with higher levels occurring during wet weather conditions in the spring and fall and lower levels occurring during dry weather conditions.

2.2 HYDROGEOLOGICAL INVESTIGATION

A Hydrogeological Investigation for the site was completed by Pinchin Ltd. and documented in their report dated January 13, 2025.

In addition to the ten boreholes described above, Pinchin Ltd. advanced four (4) groundwater test wells across the site.

The hydrogeological report confirms the quantity of groundwater available from the proposed bedrock water supply aquifer is adequate to support a 23-lot residential development. Water samples taken from the monitoring wells on the subject site to assess water quality are found to be safe for consumption based on the absence of persistent health-related exceedances. However, water treatment for aesthetic parameters may be considered on an individual lot and well basis.

In addition, there are no anticipated negative impacts to the bedrock aquifer resulting from the onsite septic treatment systems proposed for the development.



Additional details related to the geotechnical and hydrogeological investigations, conclusions and recommendations can be found in each respective report which have been submitted under separate cover.



3 Internal Roadway and Transportation

Access to the subdivision will be provided from a short extension (approximately 125m in length) of Douglas Side Road and an internal local road. Douglas Side Road will be extended into an unopened road allowance and will follow the existing road cross section geometry. Since the municipality does not have a typical rural road cross section, the proposed local road is assumed to follow a typical 20.0 m wide rural road cross section having a 6.5 m wide asphalt surface, 1.0 m wide granular shoulders and open grassed ditches, as shown on Drawing SWM-1, included at the back of this report.

Based on the findings of the geotechnical investigation, the minimum pavement structure design for the internal roadways will consist of the following:

- Surface course asphalt - 40 mm HL-3 (OPSS 1150);
- Binder course asphalt - 55 mm HL-8 (OPSS 1150);
- Granular Base Course - 150 mm OPSS 1010 granular 'A'; and
- Granular Subbase Course - 450 mm OPSS 1010 granular 'B' Type I or II.

In the future, the internal roads will be assumed by the Township who will undertake routine maintenance and snow plowing.



4 Grading

A preliminary road and ditch grading design was developed to match the existing drainage patterns within the site and the future connection to Douglas Side Road. The preliminary grades reduce earth cut and fill and rock excavation to the extent possible while matching into the existing grades along the perimeter of the site and at the existing drainage outlets. The road ditches have been designed to direct the majority of impaired stormwater runoff from the road and driveway surfaces to the proposed stormwater management facilities for water quality treatment and water quantity control. The minimum ditch depth is 1.0 m which allows for 0.3 m of vertical separation between the granular B road subbase layer and the bottom of the ditch. Minimum ditch depths measured from the edge of the ROW in areas of fill will be resolved at the detailed design stage in order to contain municipal runoff within the ROW and to minimize earthworks throughout the site.

Individual lot grading will direct the front portion of each lot to the road ditches. The side and rear yard areas will only be graded immediately around the future dwellings to good engineering standards (minimum 2.0% away from the future dwelling) thus allowing a portion of the lots to remain undisturbed and reducing the need for large earthworks and tree clearing operations.

The proposed development will be graded in a manner which will satisfy the following goals:

- Minimum road and ditch grade: 0.5%;
- Maximum road and ditch grade: 5.0%;
- Minimum lot grade around the future dwellings: 2.0%;
- Maximum lot grade around the future dwellings: 7.0%;
- Minimize rock excavation; and
- Minimize the volume of earth to be moved and balance cut with fill on the site.

The preliminary site grading is shown on the Preliminary Site Grading plan, Drawing SG-1, included at the back of this report.



5 Stormwater Management

The primary objective of the preliminary SWM plan is to demonstrate that the proposed development will not adversely impact the hydrologic cycle and surface water runoff characteristics of the area. This will be accomplished by evaluating the effect of the proposed development on local drainage conditions. Where necessary, solutions will be provided to mitigate any adverse impacts. Issues to be addressed and criteria to be met regarding drainage and SWM are summarized as follows:

- The site will be developed in accordance with all relevant municipal, provincial and agency SWM criteria;
- MECP 'Enhanced' treatment level water quality treatment will be provided, to mitigate potential impacts from the proposed development on the downstream receivers;
- All post development peak flows directed to each existing outlet will be reduced at or below existing condition peak flow rates during the 2-100-year design storm events based on the 3-hour Chicago, 6-hour Chicago, and 24-hour SCS Type II design storms;
- Runoff from all storms up to and including the 100-year storm event will be safely conveyed through the subdivision to the intended outlet; and
- Erosion and sediment control measures will be implemented during and following construction until the ultimate build-out of the site, to minimize erosion and sediment transport off-site.

5.1 EXISTING SITE DRAINAGE CONDITIONS

The existing topography, ground cover, and drainage patterns were obtained through a review of relevant background studies, available plans, the latest Land Information Ontario (LIO) LIDAR data set and a detailed topographic survey completed by Fairhall Moffatt & Woodland Limited) on June 6, 2022. Tatham also completed a site visit on April 13, 2023 to verify the existing drainage patterns and site features.

Two existing condition catchment areas were delineated within the site according to two existing surface water outlets. Each outlet is described below.

Outlet 1

The west portion of the site (Outlet 1, Catchment 101 - 6.2 ha) drains overland to the west at an average grade of 1.1% and discharges onto the neighbouring agricultural lands. Eventually, runoff



from Outlet 1 discharges into the Munro Municipal Drain before discharging into the Mississippi River.

Outlet 2

The balance of the site (Outlet 2, Catchment 102 - 16.0 ha), drains to the centrally located wetland feature within the site and south within the wetland discharging into a ditch that drains from east to west within an unopened road allowance located immediately beyond the south property boundary. Runoff within the ditch discharges to the Munro Municipal Drain and ultimately into the Mississippi River.

The existing conditions drainage patterns and outlets are illustrated on the Existing Condition Drainage Plan, Drawing DP-1, included at the back of this report.

5.2 EXTERNAL DRAINAGE CONDITIONS

External drainage conditions were evaluated using contour data from the LIO LIDAR dataset. North of the site, a swale along the rear of the Ridgmont subdivision intercepts flows from the subdivision and directs it north and south, around and away from the site. West of the site, the active agricultural lands generally drain northward away from the site. It is noted that portions of the agricultural lands to the north are tile drained as was confirmed onsite and using the Ontario Ministry of Agriculture, Food and rural Affairs 'AGMAPS' website. A manmade ditch exists immediately beyond the south property boundary, within an unopened road allowance, and intercepts runoff from the south. Lands west of the site drain westerly away from the site.

Based on the above, there is no external drainage draining into the site.

The external drainage patterns are illustrated on the External Drainage Plan, Drawing EXT-1, included at the back of this report.

5.3 EXISTING CONDITION HYDROLOGIC ANALYSIS

A hydrologic analysis of the existing condition was completed utilizing the single event Visual OTTHYMO Hydrologic Model Version 6 (VO6). Peak flow rates for storms up to and including the 100-year storm were calculated for the 3-hour Chicago, the 6-hour Chicago, and 24-hour SCS Type II design storms generated using historic rainfall data from the Macdonald Cartier International Airport Climate station (Environment and Climate Change Canada Station ID#610600), which is attached in Appendix A.

The catchment delineations were completed based on the site area proposed for development, existing ground contour information, and the environmental constraint boundaries. As noted in Section 5.2, there is no external area draining into the site. Land uses were established based on field reconnaissance and a review of available mapping. The land uses and soil information taken



from the Ministry of Agriculture, Food, and Agribusiness available mapping were used to establish the curve numbers (CN) and other catchment parameters used in the hydrologic model. The time to peak values for the catchment areas were calculated using the Bransby Williams and Airport Methods for runoff coefficients 'C' greater than and less than 0.4 respectively.

A summary of all catchment parameters established for the existing condition hydrologic model have been included in Appendix A.

Detailed calculations and Visual Otthymo modeling output are included in Appendix A with the results summarized below in Tables 1 and 2.

Table 1: Existing Condition Peak Flow Summary – Outlet 1

DESIGN STORM	CATCHMENT 101 6.2 ha (m ³ /s)		
	3-hr CHI	6-hr CHI	24-hr SCS Type II
25mm	0.026	-	-
2-Year	0.051	0.059	0.090
5-Year	0.098	0.112	0.162
10-Year	0.135	0.153	0.216
25-Year	0.188	0.210	0.292
50-Year	0.232	0.258	0.352
100-Year	0.280	0.311	0.415



Table 2: Existing Condition Peak Flow Summary - Outlet 2

DESIGN STORM	CATCHMENT 102 16.0 ha (m ³ /s)		
	3-hr CHI	6-hr CHI	24-hr SCS Type II
25mm	0.022	-	-
2-Year	0.049	0.057	0.092
5-Year	0.102	0.117	0.178
10-Year	0.145	0.165	0.245
25-Year	0.208	0.234	0.342
50-Year	0.261	0.292	0.419
100-Year	0.320	0.357	0.501

5.4 STORMWATER MANAGEMENT ALTERNATIVES

The preliminary SWM plan is subject to the review and approval of the Township, County and Mississippi Valley Conservation Authority. For intensive development SWM practices to provide both quantity and quality control of stormwater runoff are required. The MECP SWM design guidelines recommends using the following methods for stormwater management:

Lot Level Source Controls

Lot level controls include measures such as roof leader soak away pits, rear yard ponding areas, reduced grading, rear and side yard swales and other localized lot grading. Other methods of at-source stormwater management controls include Low impact development (LID) practices including rainwater harvesting, green roofs, roof downspout disconnection, infiltration trenches and chambers, vegetated filter strips and permeable pavement. These methods of stormwater control are beneficial since they reduce runoff close to the source. However, the above practices are site specific based on the existing soil, groundwater and bedrock conditions and require regular maintenance to be effective. Use of these practices is recommended but only to an extent that is achievable without requiring excessive maintenance.



Conveyance Controls

Infiltration trenches and perforated pipes are two examples of conveyance controls. Typically, these controls attempt to reduce runoff volume and attenuate peak flows on route to the downstream watershed by allowing stormwater runoff to infiltrate into the existing soil. These methods of controlling stormwater are only effective if the native soil has good drainage capabilities and groundwater and bedrock conditions allow for them to be implemented in an effective and practical manner. Poor construction practices also reduce the effectiveness of these stormwater management controls. Conveyance controls are not recommended due to the high bedrock conditions throughout the site.

End-of-Pipe Facilities

End-of-pipe facilities are typically wet ponds, dry ponds or wetlands that control stormwater runoff from larger development areas. These facilities allow stormwater to be retained and released at a controlled rate and can provide effective quality and quantity control during and following storm events. The major negative attributes of these facilities are that they require significant land area to provide the treatment controls thus the larger the development the greater the required pond size.

5.5 STORMWATER MANAGEMENT PLAN

The preliminary SWM plan has been developed recognizing the overall SWM criteria for the subdivision. The proposed internal roads and overall lot grading will be constructed to follow the existing topography of the land as much as possible to maintain the existing conditions drainage patterns, while still directing major flows overland to the proposed SWM facilities and the existing surface water outlets. The internal road design will also be constructed to a typical municipal road cross section standard with all minor and major system flows from the road right of way and front lot areas draining to the road ditches. The side and rear yard areas will only be graded immediately around the houses thus allowing a portion of the lots to remain undisturbed and reducing the need for large earthworks and tree clearing operations.

The proposed condition catchment delineations within the subdivision were completed utilizing the Draft Plan of Subdivision and the preliminary site grading design in combination with the topographic survey.

The proposed condition drainage patterns and outlets are illustrated on the Proposed Condition Drainage Plan, Drawing DP-2, included at the back of this report.

Separate SWM plans have been developed for each outlet and are described below.



Outlet 1

Runoff from Catchment 201 (2.7 ha) which consists of rear lot areas within the west portion of the subdivision will drain uncontrolled from east to west, eventually discharging at Outlet 1.

Outlet 2

Runoff from Catchment 202 (4.6 ha) which consists of internal lot areas, and internal roadways within the southwest portion of subdivision will drain to a proposed dry SWM facility (SWMF 1), via the proposed road ditches prior to discharging to the existing ditch located within the unopened road allowance. The road ditches are proposed as enhanced grassed swales consisting of 0.5 m wide flat bottoms and having minimum ditch slopes thereby encouraging filtering and settling of sediment and pollutants along the conveyance route. SWMF 1 has been designed as a dry SWM pond providing MECP basic level water quality treatment and quantity control. SWMF 1 will overcontrol flows from Catchment 202 such that the uncontrolled peak flows from Catchment 203 combined with the controlled peak flows from Catchments 202 and 204 are reduced at or below existing condition peak flow rates at Outlet 2.

Catchment 203 (11.0 ha) encompasses the existing wetland in the central portion of the subdivision, internal lot areas, and limited sections of the internal road that cannot drain to the proposed SWM Facilities due to grading constraints. Runoff from this catchment drains from north to south through the central portion of the site via a proposed internal road cross-culvert, a proposed drainage easement, and the central wetland, prior to discharging into the existing ditch within the unopened road allowance at Outlet 2. A small portion of Catchment 203 at the entrance to the site will discharge directly into the existing ditch within the unopened road allowance. Douglas Side Road and ditches on either side will be extended and re-aligned as required to accommodate the new site entrance and further design details will be provided at the detailed design stage. MECP enhanced level water quality treatment of the road runoff will be provided within the internal road ditches and the drainage easement prior to discharging into the natural wetland and from the site. From a water quantity perspective, Catchment 203 will drain uncontrolled from the site.

Catchment 204 (3.9 ha) which consists of internal lot areas, and internal roadways within the northeast portion of subdivision, drains to a proposed SWM facility (SWMF 2), via the proposed road ditches, prior to discharging to the existing wetland, and ultimately to Outlet 2. The road ditches are proposed as enhanced grassed swales thereby providing MECP Enhanced level water quality treatment upstream of SWMF 2. SWMF 2 has been designed as a dry SWM facility providing MECP basic level water quality treatment and will overcontrol peak flows from Catchment 204 up to and including the 100-year storm such that the uncontrolled peak flows



from Catchment 203 combined with the controlled peak flows from Catchments 202 and 204 are reduced at or below the existing condition peak flow rates at Outlet 2.

SWM Facility Design Criteria

The detailed design of the dry SWM facilities will consider the following:

- Sizing of the stormwater quantity control component of the facilities must ensure the post development peak runoff rates from the site are reduced at or below existing conditions and must be exclusive of the storage needed for the quality control component based on current MECP design guidelines;
- Sizing of the stormwater quality control component of the facilities must achieve 'basic' level protection and erosion control and thus the facilities must have water quality control volumes as determined using Table 3.2 of the MECP SWM design guidelines. 24 hour extended detention of the 25 mm storm runoff volume must also be provided for erosion control;
- Any overtopping of the SWM facilities must be safely conveyed to the receiving drainage path;
- Optimization of suspended solids and heavy metal removal efficiencies by locating minor system inlets and SWM facility outlets as far apart as possible to prevent short circuiting;
- Optimize nutrient uptake potential and diversity of plantings to enhance local aquatic and wildlife habitats; and
- Consider operation and maintenance requirements and frequency and include as part of the design process.

5.5.1 Water Quantity Control

A hydrologic analysis of the post development condition was completed utilizing the single event Visual OTTHYMO Hydrologic Model (VO6). Peak flow rates for storms up to and including the 100-year storm were calculated for the 3-hour Chicago, the 6-hour Chicago, and 24-hour SCS Type II design storms generated using historic rainfall data as described in Section 5.3 above.

The catchment delineation for the contributing lands were completed utilizing the Draft Plan of Subdivision and the preliminary site grading designs in combination with the topographic survey. The total impervious (TIMP) and percent directly connected imperviousness for the future lot development was calculated based on 200 m² average dwelling footprint areas and 6-metre-wide driveways each 17 m long. A summary of all catchment parameters established for the post development hydrologic model have been included in Appendix A.



The time to peak values for the individual catchment areas were calculated using either the Bransby Williams and Airport Methods for runoff coefficient “C” values greater than and less than 0.4 respectively.

Preliminary stage-storage-discharge data was input into the ‘route reservoir’ commands of the hydrologic model to confirm the quantity control storage requirements and that the corresponding land allocation for the SWM facility blocks are appropriate. Specific details relating to the pond outlet control structures will be determined at the detailed design stage.

Detailed calculations and Visual Otthymo modeling output are included in Appendix A with the results summarized below in Tables 3 and 4.

Table 3: Proposed Condition Peak Flow Summary - Outlet 1

DESIGN STORM	CATCHMENT 201 2.7 ha (m ³ /s)		
	3-hr CHI	6-hr CHI	24-hr SCS Type II
25mm	0.014 (0.026)	-	-
2-Year	0.027 (0.051)	0.031 (0.059)	0.047 (0.090)
5-Year	0.051 (0.098)	0.058 (0.112)	0.084 (0.162)
10-Year	0.07 (0.135)	0.079 (0.153)	0.111 (0.216)
25-Year	0.096 (0.188)	0.108 (0.210)	0.149 (0.292)
50-Year	0.118 (0.232)	0.132 (0.258)	0.179 (0.352)
100-Year	0.143 (0.280)	0.159 (0.311)	0.211 (0.415)

Notes: (0.026) refers to the existing condition peak flow rate.



Table 4: Proposed Condition Peak Flow Summary – Outlet 2

DESIGN STORM	CATCHMENT 202 4.6 ha (m ³ /s)			CATCHMENT 203 11.0 ha (m ³ /s)			CATCHMENT 204 3.9.0 ha (m ³ /s)			TOTAL OUTLET 2		
	3-hr CHI	6-hr CHI	24-hr SCS Type II	3-hr CHI	6-hr CHI	24-hr SCS Type II	3-hr CHI	6-hr CHI	24-hr SCS Type II	3-hr CHI	6-hr CHI	24-hr SCS Type II
25 mm	0.000	-	-	0.022	-	-	0.000	-	-	0.022 (0.022)	-	-
2-Year	0.000	0.001	0.001	0.047	0.055	0.089	0.001	0.001	0.002	0.048 (0.049)	0.056 (0.057)	0.090 (0.092)
5-Year	0.001	0.001	0.004	0.096	0.11	0.168	0.002	0.002	0.005	0.098 (0.102)	0.112 (0.117)	0.170 (0.178)
10-Year	0.001	0.003	0.006	0.136	0.155	0.229	0.003	0.005	0.009	0.138 (0.145)	0.157 (0.165)	0.235 (0.245)
25-Year	0.003	0.005	0.009	0.194	0.218	0.316	0.006	0.009	0.015	0.198 (0.208)	0.223 (0.234)	0.327 (0.342)
50-Year	0.004	0.007	0.013	0.242	0.271	0.385	0.009	0.012	0.019	0.248 (0.261)	0.278 (0.292)	0.403 (0.419)
100-Year	0.006	0.009	0.016	0.295	0.331	0.459	0.012	0.016	0.024	0.305 (0.320)	0.341 (0.357)	0.482 (0.501)

Notes: (0.022) refers to the existing condition peak flow rate.



A comparison of the tables above showing the post-development peak flow summaries with the existing condition peak flows confirms the SWM plans for each outlet can attenuate the 2-year through 100-year post-development peak flows at or below existing peak flow rates.

SWMF 1 is a dry pond and has approximately 2,159 m³ of active storage and an additional 0.3 m of freeboard as illustrated on Drawing SWM-1, whereas 1,990 m³ of active storage is required during the 100-year 24-hour SCS design storm.

SWMF 2 is also a dry pond and has approximately 1,216 m³ of active storage and an additional 0.3 m of freeboard, whereas 1,156 m³ of active storage is required during the 100-year 24-hour SCS design storm.

Preliminary stage-volume tables for each facility are included in Appendix A.

5.5.2 Water Quality Control

The proposed water quality control plan for the development will follow a treatment train approach consisting of enhanced 0.5 m wide flat bottom grassed swales in the road ditches and dry SWM ponds that are equipped with plunge pools within the pond forebays and a low flow channel between the pond inlet and the outlet. Within each individual lot, all roof leaders will be directed to pervious front and rear lot areas further promoting filtration of runoff and infiltration upstream of the conveyance route.

Water quality control plans have been developed for each outlet and are described below. The water quality control design calculations are attached in Appendix A. It is noted that the water quality control calculations and storage volumes provided within each SWM facility do not consider the additional water quality treatment from directing roof leaders to pervious front and rear lot areas and thus are conservative as it relates to water quality treatment of runoff from the proposed development.

Outlet 1

Runoff from Catchment 201 consists of rooftop and rear yard runoff and is unimpaired from a water quality perspective. On this basis, was quality treatment for runoff from Outlet 1 is not warranted or required.

Outlet 2

Enhanced 0.5 m Wide Flat Bottom Grassed Swales

Runoff from the road and driveways within Catchments 202, 203 and 204 will be captured by the road ditches which have been enhanced with 0.5 m wide flat bottoms and reduced longitudinal slopes (0.5% - 2.9%) thereby reducing flow velocities and promoting filtering and settling of sediment and pollutants. In accordance with the MECF SWM manual, enhanced grassed swales



are effective at providing water quality treatment when the maximum peak flow velocity does not exceed 0.5 m/s during a 4-hour, 25 mm storm event. Typically, enhanced grassed swales are effective for drainage areas up to 2.0 ha however for low impervious areas including Catchment 202 (15% impervious), Catchment 203 (4% impervious) and Catchment 204 (8% impervious), the flow velocity is the more stringent requirement.

The maximum ditch velocity during the 25 mm storm event within all of the above catchments is within Catchment 202 and was determined to be 0.22 m/s which is less than the velocity threshold for providing enhanced water quality treatment. Further water quality treatment is provided within the proposed dry ponds downstream of the proposed enhanced grassed swales in Catchments 202 and 204.

The enhanced ditch velocity calculations are attached in Appendix A.

Dry SWM Facility

Catchment 202 (4.6 ha) has an estimated imperviousness of 15%. As per the MECP design guidelines the larger of the erosion control active storage (25 mm storm runoff volume) and the water quality active storage (MECP Table 3.2) is to be detained a minimum of 24 hours. The water quality storage requirement from MECP Table 3.2 was determined to be 143.2 m³ whereas the erosion control active storage volume was determined to be 161.9 m³ and therefore is the more stringent volume criteria. It is noted that SWMF 1 has approximately 2,159 m³ of active storage and the water quality active storage requirement will make up a portion of the water quantity control storage volume. Based on the above, SWMF 1 will provide basic level (60% TSS removal) water quality treatment of runoff from Catchment 202 in addition to the MECP enhanced level treatment provided in the upstream enhanced 0.5 m flat bottom grassed swales.

Catchment 204 (3.9 ha) has an estimated imperviousness of 8%. As per the MECP design guidelines the larger of the erosion control active storage (25 mm storm runoff volume) and the water quality active storage (MECP Table 3.2) is to be detained a minimum of 24 hours. The water quality storage requirement from MECP Table 3.2 was determined to be 37.6 m³ whereas the erosion control active storage volume was determined to be 83.9 m³ and therefore is the more stringent volume criteria. It is noted that SWMF 2 has approximately 1,216 m³ of active storage and the water quality active storage requirement will make up a portion of the water quantity control storage volume. Based on the above, SWMF 2 will provide basic level (60% TSS removal) water quality treatment of runoff from Catchment 202 in addition to the MECP enhanced level treatment provided in the upstream enhanced 0.5 m flat bottom grassed swales.



Vehicular access to SWMF 1 and 2 will be provided via maintenance access roads which have been allowed for in the SWM block sizing which are depicted on Drawings SG-1.

5.6 STORMWATER CONVEYANCE

Minor and major system drainage will be conveyed in the road ditches, culverts, easements and the SWM blocks to the intended outlets. The enhanced road ditches will be sized to convey peak flows from all storms up to and including the 100-year storm. Enhanced road ditch capacity calculations, confirming that the proposed enhanced grassed swales can convey the 100-year storm peak flow from the largest contributing drainage area (Catchment area 202) at a depth of less than 0.15 m, are included in Appendix A.

The proposed road cross culverts will be sized to convey the peak runoff rate from storms up to and including the 25-year storm prior to overtopping the road. The proposed driveway culverts will be designed to convey the 5-year storm peak flow rate at a minimum. The proposed culvert sizing calculations will be provided at the detailed design stage.



6 Siltation and Erosion Control

Siltation and erosion control measures will be implemented for all construction activities within the site including vegetation clearing, topsoil stripping, grading, and stockpiling of materials. The basic principles considered to minimize erosion, sedimentation and resultant negative environmental impacts include:

- All erosion control devices to be specified in accordance with the Erosion and Sediment Control Guide for Urban Construction (Sustainable Technologies Evaluation Program, 2019);
- Silt control fences to be erected before the commencement of any grading operations to control sediment movement;
- A designated construction vehicle entrance(s) with a stone mud mat will be specified to reduce off-site tracking of material;
- Temporary swales, and earth berms will be constructed to control runoff during construction by lowering velocities and promoting settling of particulates;
- All topsoil and fill piles are to be surrounded with heavy duty silt fence and are to be seeded immediately upon completion of earthworks;
- Expose the smallest possible land area to erosion for the shortest possible time;
- Long term siltation and erosion control will be enhanced with a re-vegetation strategy for disturbed areas;
- Confine refuelling and servicing of equipment to areas well away from the drainage systems; and
- Regular inspection of control measures to be instituted through a monitoring and mitigation plan and repairs will be made as necessary. Bi-weekly inspections of the site erosion and sediment control should be completed.

A detailed erosion and sediment control plan will be prepared at the detailed design stage.



7 Summary

The proposed SWM plan demonstrates how existing drainage conditions will generally be maintained to the existing surface water outlets. Stormwater management facilities consisting of enhanced grassed swales in the road ditches and two dry ponds are proposed and are sufficient to provide MEP enhanced level water quality treatment and water quantity controls. At-source LID practices consisting of roof leaders directed to pervious areas will also be provided thereby providing a treatment train approach to water quality control. The detailed design of SWM plans for each outlet will be provided at the detailed design stage, however the work completed to date confirms that appropriate stormwater management can be provided to support the proposed development.

Siltation and erosion control will be provided with the proper construction mitigation efforts. Long-term erosion control will be enhanced with an effective revegetation strategy.

We trust this report demonstrates the feasibility of the proposed subdivision as it relates to stormwater management and is sufficient to support the proposed Draft Plan of subdivision application.



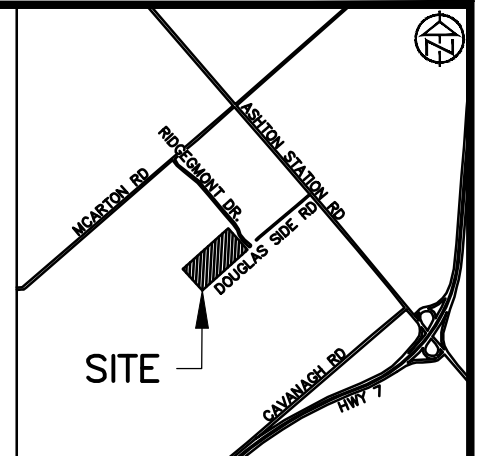

KEY PLAN



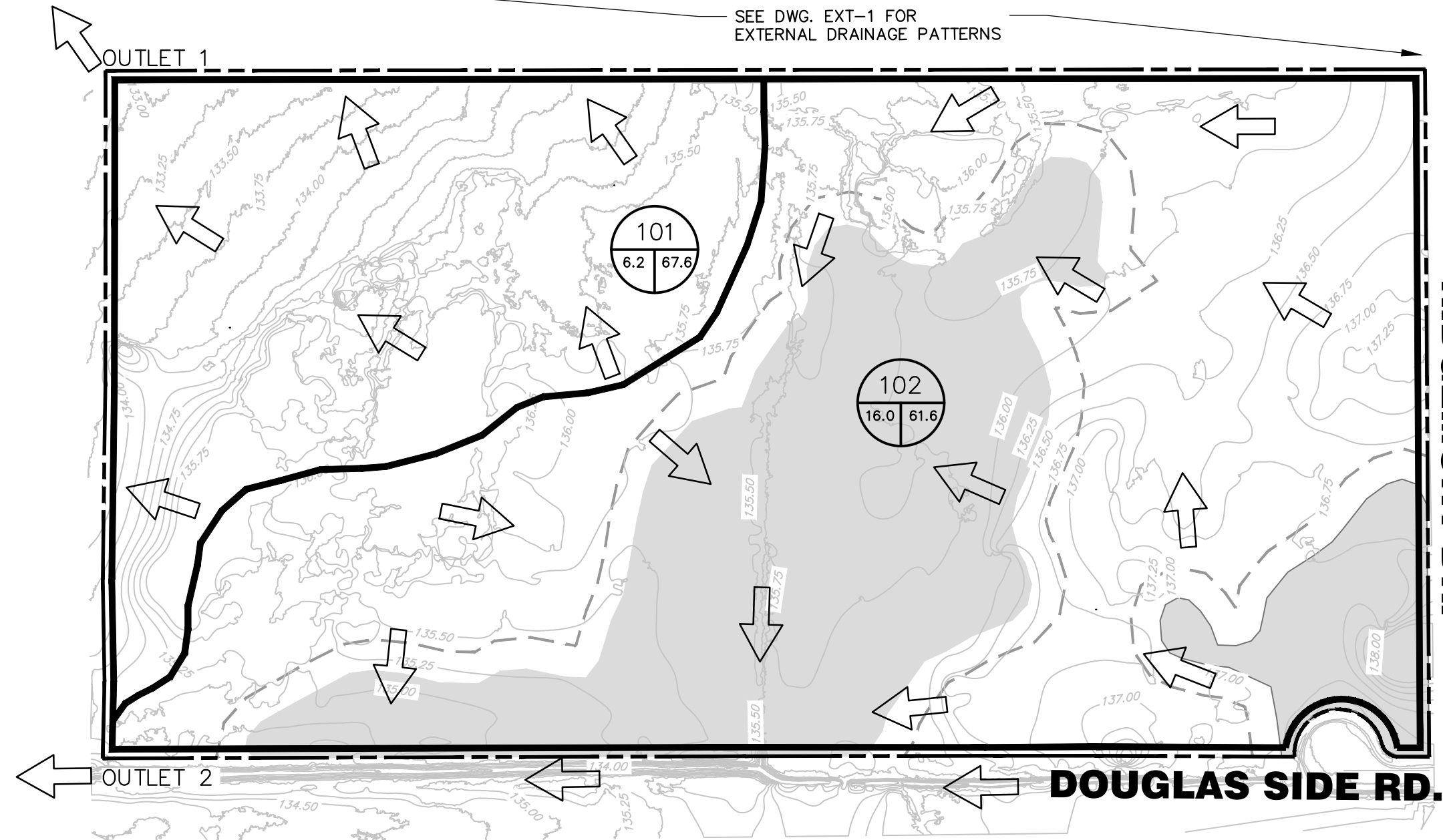



SEE DWG. EXT-1 FOR
EXTERNAL DRAINAGE PATTERNS



RIDGEMONT DR.

DOUGLAS SIDE RD.

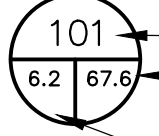
LEGEND

-  SUBJECT PROPERTY BOUNDARY
-  DRAINAGE AREA BOUNDARY
-  ENVIRONMENTAL CONSTRAIN AREA
-  EXISTING CONDITION DRAINAGE DIRECTION
-  DRAINAGE AREA ID
CURVE NUMBER
-  AREA (ha.)

CONTRACT DRAWINGS

CONTRACTOR MUST VERIFY ALL DIMENSIONS AND BE RESPONSIBLE FOR SAME. ANY DISCREPANCIES MUST BE REPORTED TO THE ENGINEER BEFORE COMMENCING WORK. DRAWINGS ARE NOT TO BE SCALED.

TATHAM ENGINEERING LIMITED CLAIMS COPYRIGHT TO THIS DOCUMENT WHICH MAY NOT BE USED FOR ANY PURPOSE OTHER THAN THAT PROVIDED IN THE CONTRACT BETWEEN THE OWNER/CLIENT AND THE ENGINEER WITHOUT THE EXPRESS CONSENT OF TATHAM ENGINEERING LIMITED.

TOPOGRAPHIC LIDAR SURVEY WAS COMPLETED BY FAIRHALL, MOFFAT & WOODLAND LTD.

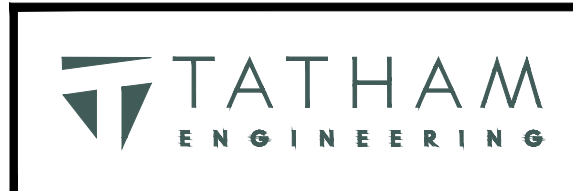

DOUGLAS LANDING SUBDIVISION BECKWITH TOWNSHIP LANARK COUNTY EXISTING CONDITION DRAINAGE PLAN		DWG. No. DP-1
SCALE: 1:2500	DRAWN: DVF	DATE: APR, 2023
		JOB NO. 522650

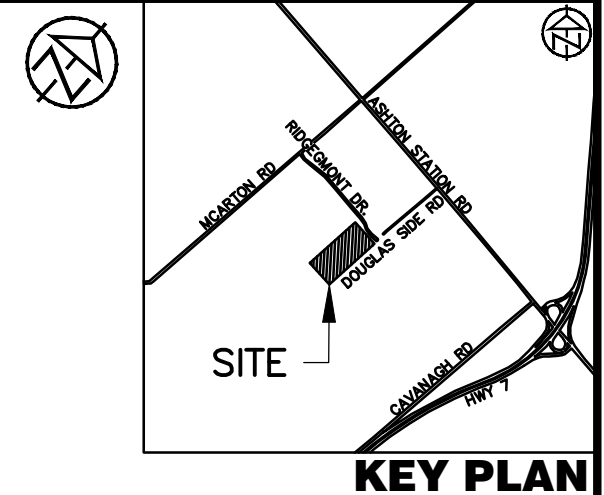

SEE DWG. EXT-1 FOR EXTERNAL DRAINAGE PATTERNS

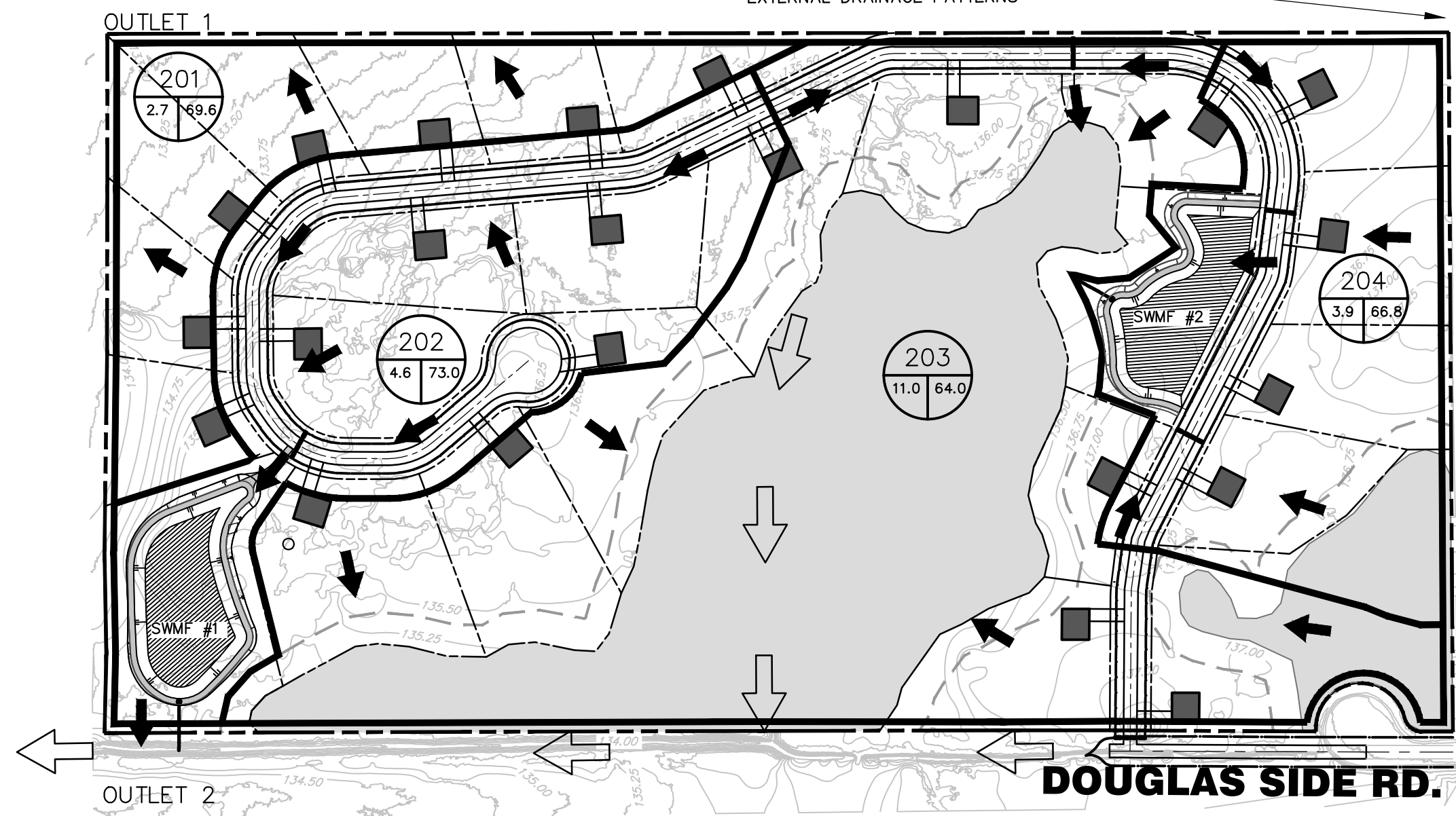

RIDGEMONT DR.

DOUGLAS SIDE RD.

LEGEND

- SUBJECT PROPERTY BOUNDARY
- DRAINAGE AREA BOUNDARY
- ENVIRONMENTAL CONSTRAIN AREA
- EXISTING CONDITION DRAINAGE DIRECTION
- PROPOSED CONDITION DRAINAGE DIRECTION
- 201**
2.7 | 69.6
DRAINAGE AREA ID
CURVE NUMBER
AREA (ha.)

CONTRACT DRAWINGS

CONTRACTOR MUST VERIFY ALL DIMENSIONS AND BE RESPONSIBLE FOR SAME. ANY DISCREPANCIES MUST BE REPORTED TO THE ENGINEER BEFORE COMMENCING WORK. DRAWINGS ARE NOT TO BE SCALED.

TATHAM ENGINEERING LIMITED CLAIMS COPYRIGHT TO THIS DOCUMENT WHICH MAY NOT BE USED FOR ANY PURPOSE OTHER THAN THAT PROVIDED IN THE CONTRACT BETWEEN THE OWNER/CLIENT AND THE ENGINEER WITHOUT THE EXPRESS CONSENT OF TATHAM ENGINEERING LIMITED.

TOPOGRAPHIC LIDAR SURVEY WAS COMPLETED BY FAIRHALL, MOFFAT & WOODLAND LTD.

	DOUGLAS LANDING SUBDIVISION BECKWITH TOWNSHIP LANARK COUNTY PROPOSED CONDITION DRAINAGE PLAN		DWG. No. DP-2
	SCALE: 1:2500	DRAWN: HY	DATE: JAN. 2025

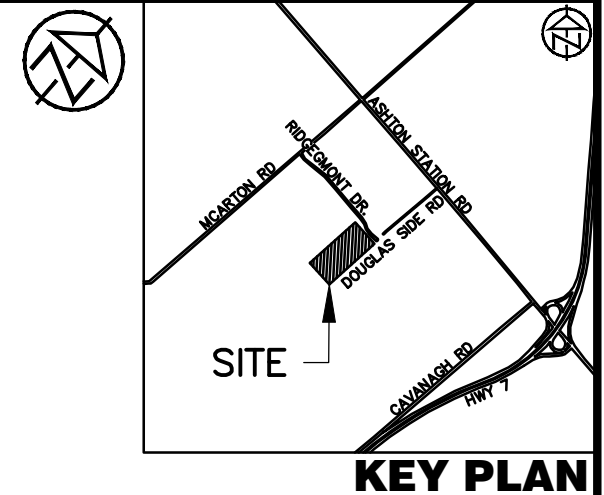

- LEGEND**
- SUBJECT PROPERTY BOUNDARY
 - DRAINAGE DIRECTION

CONTRACT DRAWINGS
 CONTRACTOR MUST VERIFY ALL DIMENSIONS AND BE RESPONSIBLE FOR SAME. ANY DISCREPANCIES MUST BE REPORTED TO THE ENGINEER BEFORE COMMENCING WORK. DRAWINGS ARE NOT TO BE SCALED.
 TATHAM ENGINEERING LIMITED CLAIMS COPYRIGHT TO THIS DOCUMENT WHICH MAY NOT BE USED FOR ANY PURPOSE OTHER THAN THAT PROVIDED IN THE CONTRACT BETWEEN THE OWNER/CLIENT AND THE ENGINEER WITHOUT THE EXPRESS CONSENT OF TATHAM ENGINEERING LIMITED.

TOPOGRAPHIC LIDAR SURVEY WAS COMPLETED BY FAIRHALL, MOFFAT & WOODLAND LTD.

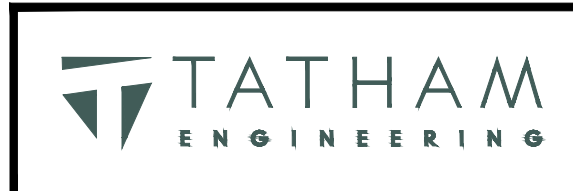

DOUGLAS LANDING SUBDIVISION BECKWITH TOWNSHIP LANARK COUNTY EXTERNAL DRAINAGE PLAN			DWG. No. EXT-1
SCALE: 1:5000	DRAWN: HY	DATE: JAN. 2025	JOB NO. 522650

METRIC
DISTANCES AND ELEVATIONS SHOWN ON THIS PLAN ARE IN METRES
AND CAN BE CONVERTED TO FEET BY DIVIDING BY 0.3048

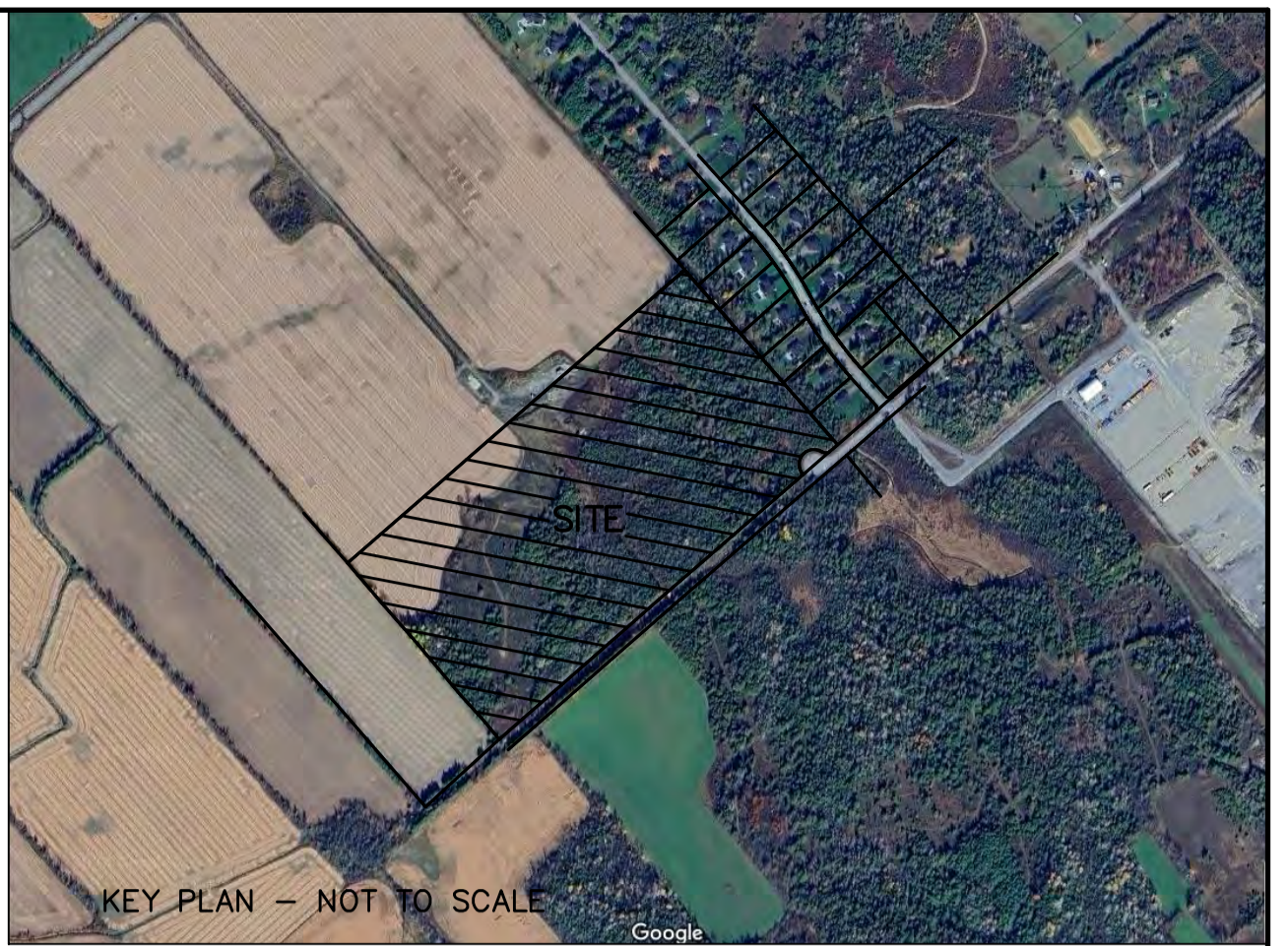
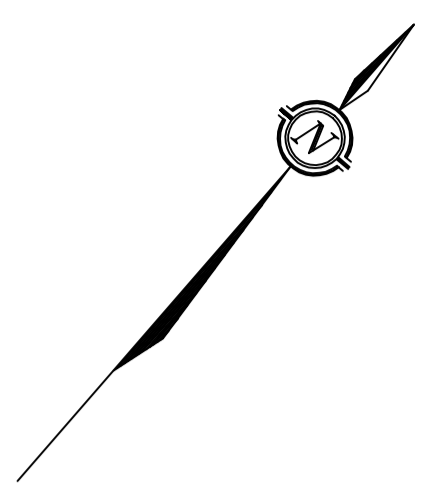

KEY PLAN - NOT TO SCALE

**DRAFT PLAN OF SUBDIVISION OF
PART OF LOT 25
CONCESSION 12
TOWNSHIP OF BECKWITH
COUNTY OF LANARK**

SCALE 1 : 1000
0 10 20 50 100 metres
FAIRHALL, MOFFATT & WOODLAND LIMITED
ONTARIO LAND SURVEYORS

OWNER'S AUTHORIZATION

I HEREBY AUTHORIZE THE SUBMISSION OF THIS PLAN FOR APPROVAL.
DOUGLAS LANDING DEVELOPMENTS

DATE _____ DR. GILLIAN ESPIE (PRESIDENT)

SURVEYOR'S CERTIFICATE

I HEREBY CERTIFY THAT THE BOUNDARIES OF THE LANDS TO BE SUBDIVIDED AS SHOWN ON THIS PLAN AND THEIR RELATIONSHIP TO ADJOINING LANDS ARE ACCURATELY AND CORRECTLY SHOWN.

DATE _____ JOHN H. GUTRI (ONTARIO LAND SURVEYOR)

SECTION 51 (17) OF THE PLANNING ACT.

- a) SHOWN ON PLAN
- b) SHOWN ON PLAN
- c) SHOWN ON PLAN
- d) 19 LOTS FOR SINGLE FAMILY HOMES (2 STOREYS EACH)
4 LOTS FOR ATTAINABLE HOUSING
WETLAND
STORMWATER MANAGEMENT
- e) SHOWN ON PLAN
- f) SHOWN ON PLAN
- g) SHOWN ON PROJECT SITE PLAN
- h) WATER SUPPLY WILL BE FROM WELLS AS SHOWN ON CONCEPT PLAN BY P2 CONCEPTS DATED JAN. 13, 2025. ALSO SEE HYDROLOGICAL REPORT BY PINCHIN LTD. DATED JAN. 13, 2025.
- i) SEE GEOTECHNICAL INVESTIGATION REPORT BY PINCHIN LTD. DATED JAN. 13, 2025.
- j) SEE GRADING AND DRAINAGE PLAN BY TATHAM ENGINEERING LIMITED DATED JAN. 13, 2025.
- k) FIRE PROTECTION, POLICING AND GARBAGE COLLECTION ARE AVAILABLE.
- l) NONE REGISTERED

SITE AREA = 22.181 Ha.

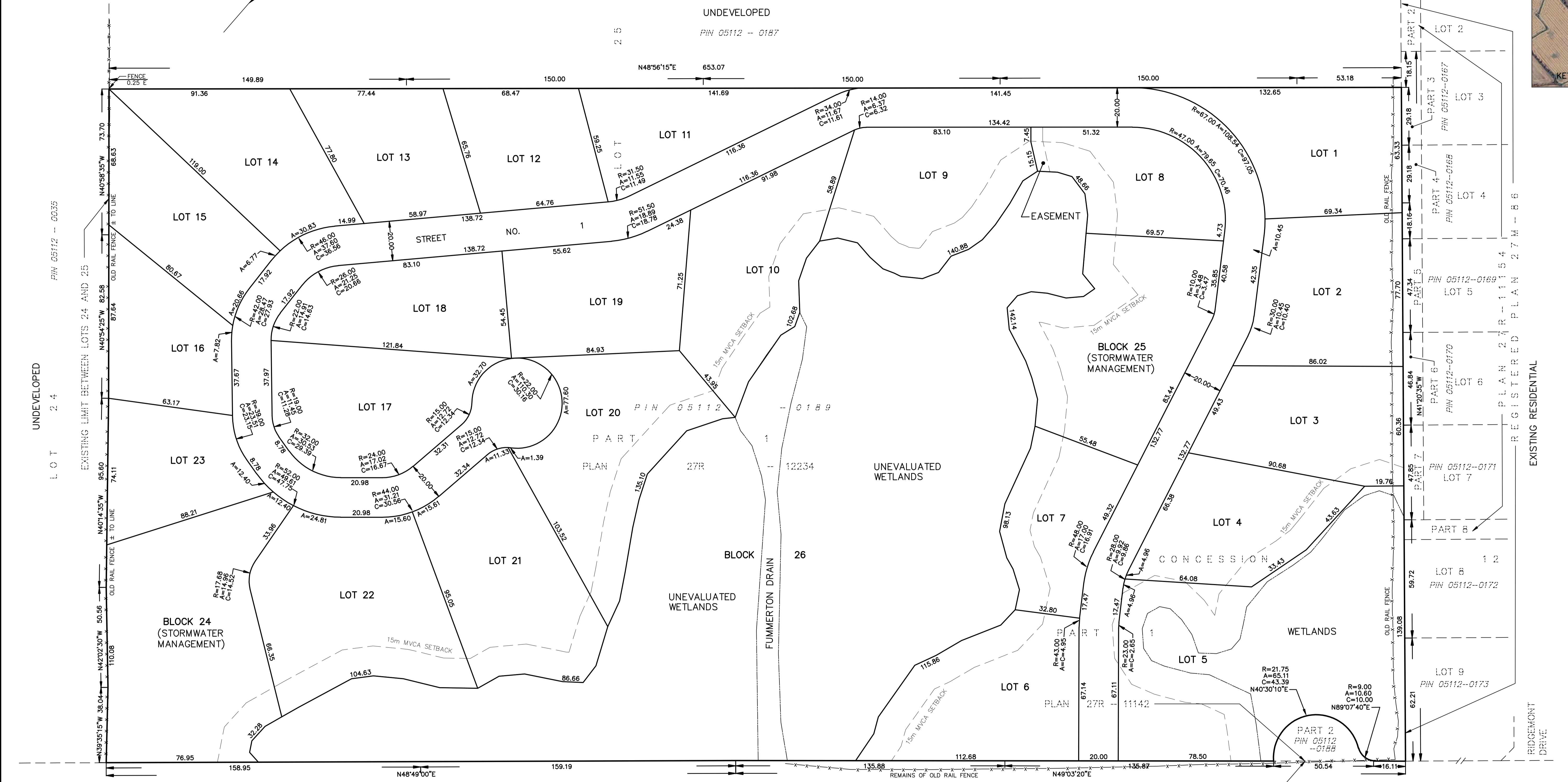

ROAD ALLOWANCE BETWEEN CONCESSIONS 11 AND 12 (NOT TRAVELLED)

PIN 05112 -- 0016

ROAD ALLOWANCE BETWEEN CONCESSIONS 11 AND 12 (KNOWN AS) DOUGLAS SIDE ROAD

© COPYRIGHT 2024. REPRODUCTION, ALTERATION OR DISTRIBUTION OF THIS PLAN WITHOUT THE WRITTEN CONSENT OF FAIRHALL, MOFFATT & WOODLAND LIMITED IS PROHIBITED.

Fairhall Moffatt & Woodland LIMITED ONTARIO LAND SURVEYORS Surveying and Land Information Services 100-600 TERRY FOX DRIVE, KANATA, ONTARIO K2L 4B6 TEL: (613) 591-2580 FAX: (613) 591-1465 www.fmw.on.ca	JOB No. AC13300
	E 337908, N 5004285
	REFERENCE No. 226 - 12 BECKWITH S:\0585\AC13300\DWG\act133_draft-plan.dwg (kg)

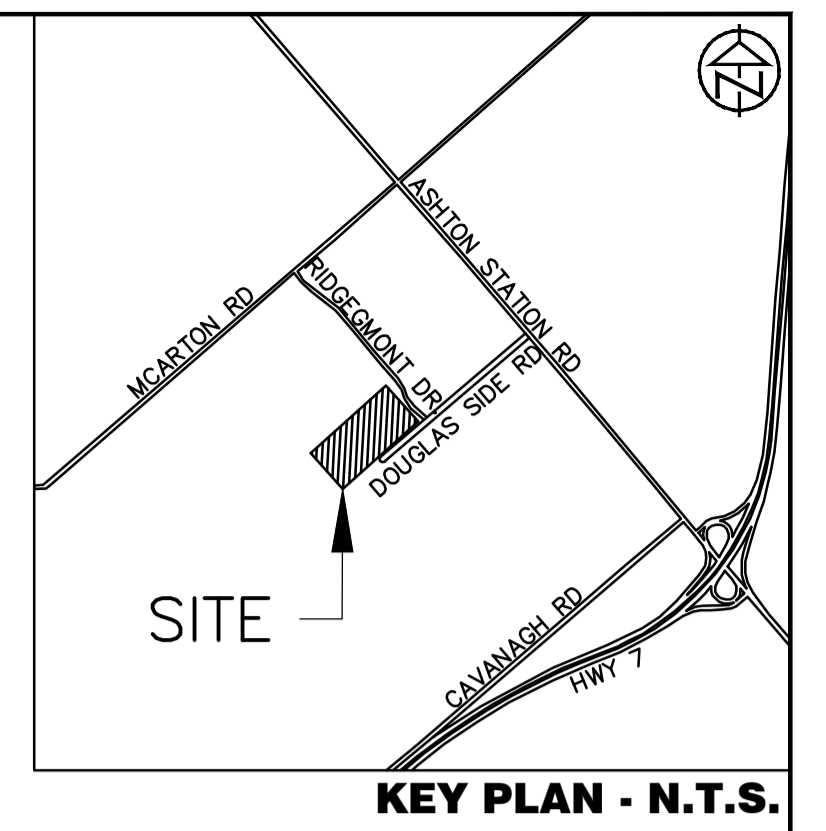
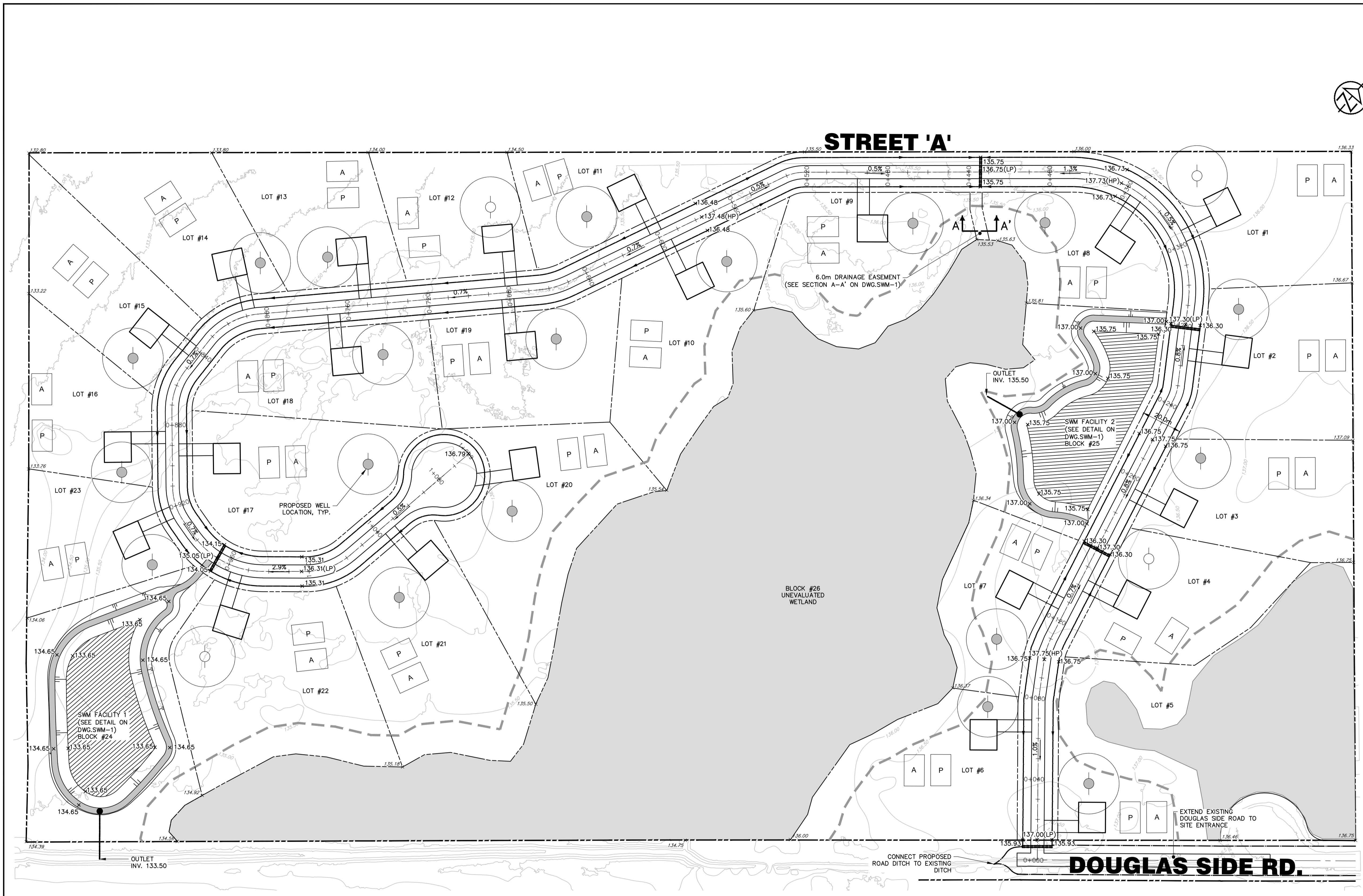

RIDGEMONT DR.

LEGEND

- 221.35 — EXISTING CONTOUR
- × 221.35 EXISTING ELEVATION
- × 262.25 PROPOSED ELEVATION
- ***** PROPOSED CULVERT
- LOT LINE
- PROPOSED SWALE AND FLOW DIRECTION
- PROPERTY BOUNDARY
- ENVIRONMENTAL CONSTRAIN AREA
- LOCAL WETLAND AREA

DISCLAIMER AND COPYRIGHT

CONTRACTOR MUST VERIFY ALL DIMENSIONS AND BE RESPONSIBLE FOR SAME. ANY DISCREPANCIES MUST BE REPORTED TO THE ENGINEER BEFORE COMMENCING WORK. DRAWINGS ARE NOT TO BE SCALED.

TATHAM ENGINEERING LIMITED CLAIMS COPYRIGHT TO THIS DRAWING WHICH MAY NOT BE USED FOR ANY PURPOSE OTHER THAN THAT PROVIDED IN THE CONTRACT BETWEEN THE OWNER/CLIENT AND THE ENGINEER WITHOUT THE EXPRESS CONSENT OF TATHAM ENGINEERING LIMITED.

TOPOGRAPHIC LIDAR SURVEY WAS COMPLETED BY FAIRHALL, MOFFAT & WOODLAND LTD.

No.	REVISION DESCRIPTION	DATE	ENGINEER STAMP

No.	REVISION DESCRIPTION	DATE	ENGINEER STAMP

DOUGLAS LANDING SUBDIVISION
BECKWITH TOWNSHIP
LANARK COUNTY

PRELIMINARY SITE GRADING PLAN

TATHAM ENGINEERING

DESIGN: HY FILE: 522650 DWG:
DRAWN: HY DATE: JAN 2025 **SG-1**
CHECK: JA SCALE: SCALE 1:1000

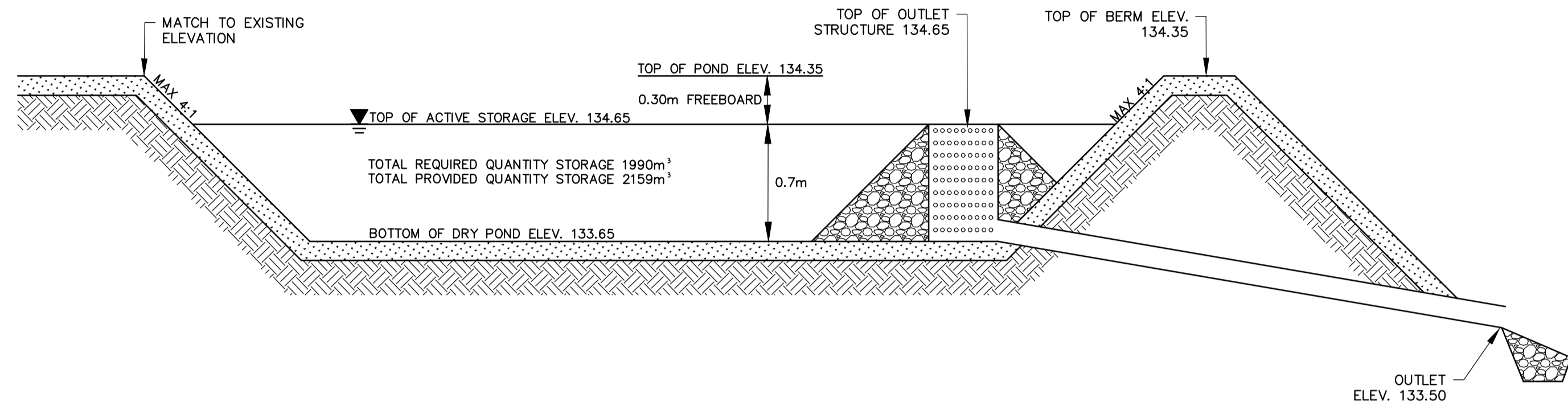

TYPICAL SWM FACILITY 1 (DRY POND) CROSS SECTION

SCALE: N.T.S

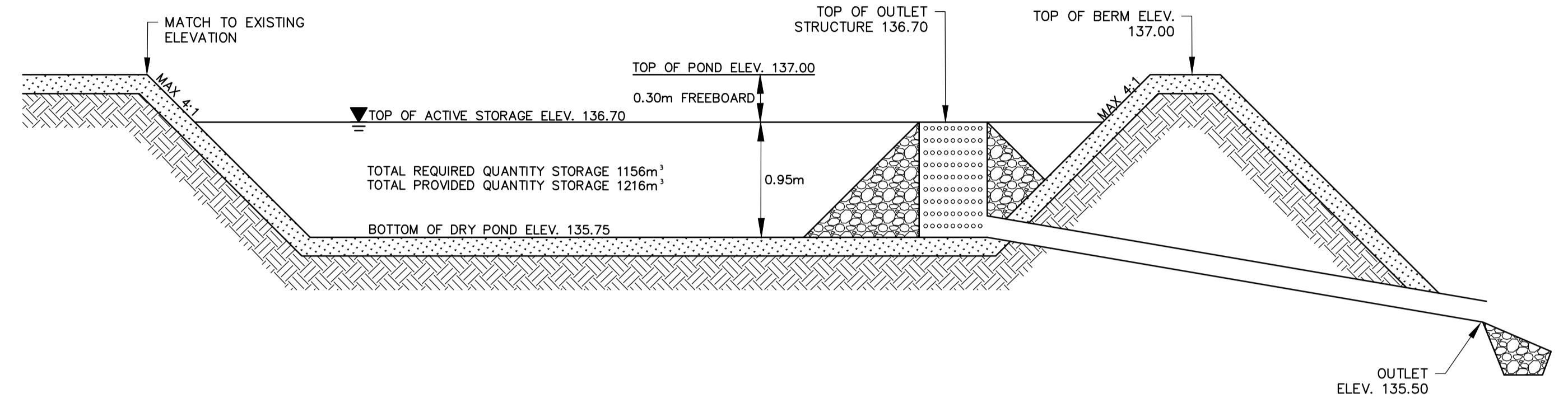

TYPICAL SWM FACILITY 2 (DRY POND) CROSS SECTION

SCALE: N.T.S

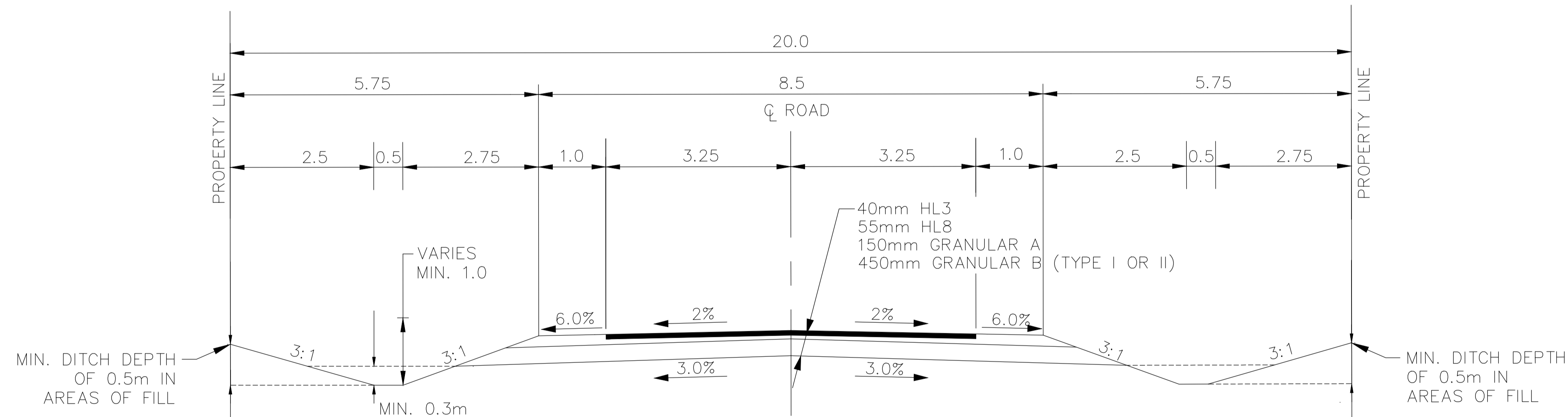

TYPICAL ROAD CROSS SECTION (20m R.O.W)

NTS

NOTE:

1. A MAXIMUM DITCH SIDE SLOPE OF 2.5:1 SHALL BE USED ONLY WHERE A 3:1 SIDE SLOPE IS UNATTAINABLE DUE TO GRADING RESTRICTIONS.
2. GRANULAR B THICKNESS TO BE REDUCED TO A MINIMUM OF 300mm IN AREAS WHERE BED ROCK ENCRACHES THE SUBBASE UNDER THE SUPERVISION OF A GEOTECHNICAL ENGINEER. WHERE THE ROAD SUBBASE CONSISTS OF BEDROCK, THE SURFACE OF ROCK IS TO BE SLOPED AS SHOWN IN THE CROSS SECTION TO ELIMINATE THE POTENTIAL FOR TRAPPED WATER UNDER THE ROAD

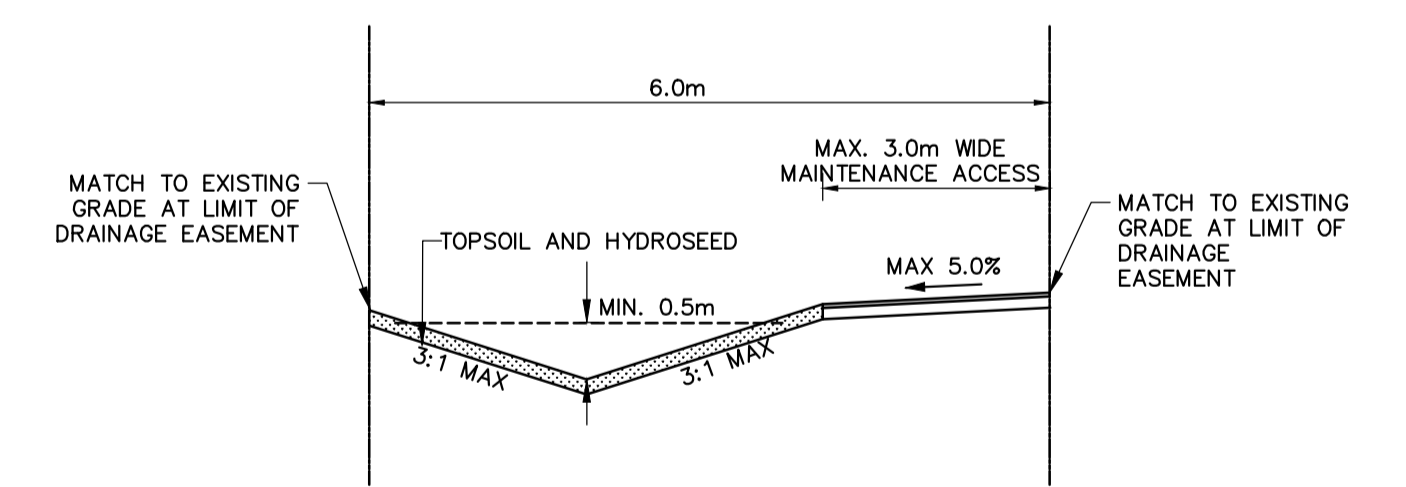

6.0m WIDE DRAINAGE EASEMENT DETAIL (TYPICAL)

SCALE: NTS

DISCLAIMER AND COPYRIGHT

CONTRACTOR MUST VERIFY ALL DIMENSIONS AND BE RESPONSIBLE FOR SAME. ANY DISCREPANCIES MUST BE REPORTED TO THE ENGINEER BEFORE COMMENCING WORK. DRAWINGS ARE NOT TO BE SCALED.

TATHAM ENGINEERING LIMITED CLAIMS COPYRIGHT TO THIS DRAWING WHICH MAY NOT BE USED FOR ANY PURPOSE OTHER THAN THAT PROVIDED IN THE CONTRACT BETWEEN THE OWNER/CLIENT AND THE ENGINEER WITHOUT THE EXPRESS CONSENT OF TATHAM ENGINEERING LIMITED.

TOPOGRAPHIC LIDAR SURVEY WAS COMPLETED BY FAIRHALL, MOFFAT & WOODLAND LTD.

No.	REVISION DESCRIPTION	DATE	ENGINEER STAMP

DOUGLAS LANDING SUBDIVISION
BECKWITH TOWNSHIP
LANARK COUNTY

PRELIMINARY STORMWATER
MANAGEMENT PLAN



DESIGN: HY	FILE: 522650	DWG:
DRAWN: HY	DATE: JAN 2025	SWM-1
CHECK: JA	SCALE:	

Appendix A: Stormwater Management Calculations

Visual OTTHYMO Model Parameter Calculations (NasHYD)

Project Details

Project Number	522650
----------------	--------

Data Sources

Detailed Soil Survey Reports for Ontario, MTO Drainage Management Manual (1997)

Prepared By

Name	HY
------	----

Pre-Development Condition

Watershed:	N/A
Catchment ID:	101
Catchment Area (ha):	6.20
Impervious %:	

Average Curve Number (CN), Runoff Coefficient (C) and Initial Abstraction (IA)

Soil Symbol	FI				Os									
Soil Series	Farmington				Osgoode									
Hydrologic Soils Group	B				B									
Soil Texture	Loam or Silt Loam				Silt Loam									
Runoff Coefficient Type	2				2									
Area (ha)	2.90				3.30									
Percentage of Catchment	47%				53%									
Land Cover Category	IA	A (ha)	CN	C	A (ha)	CN	C	A (ha)	CN	C	A (ha)	CN	C	
Impervious	2		100	0.95		100	0.95							
Gravel	3		89	0.27		89	0.27							
Woodland	10	0.37	60	0.25	0.58	60	0.25							
Pasture/Lawns	5	2.53	69	0.28	2.72	69	0.28							
Meadows	8		65	0.27		65	0.27							
Cultivated	7		74	0.35		74	0.35							
Waterbody	12		50	0.05		50	0.05							
Average CN	67.85				67.42									
Average C	0.28				0.27									
Average IA	5.64				5.88									

Time to Peak Calculations

Max. Catchment Elev. (m):	136.25
Min. Catchment Elev. (m):	133.00
Catchment Length (m):	285
Catchment Slope (%):	1.14%
Method: Airport Method	
Time of Concentration (mins):	43.46

Summary

Catchment CN:	67.6
Catchment C:	0.28
Catchment IA (mm):	5.77
Time of Concentration (hrs):	0.72
Catchment Time to Peak (hrs):	0.48
Catchment Time Step (mins):	5.79

Visual OTTHYMO Model Parameter Calculations (NasHYD)

Project Details

Project Number	522650
----------------	--------

Data Sources

Detailed Soil Survey Reports for Ontario, MTO Drainage Management Manual (1997)

Prepared By

Name	HY
------	----

Pre-Development Condition

Watershed:	N/A
Catchment ID:	102
Catchment Area (ha):	16.00
Impervious %:	

Average Curve Number (CN), Runoff Coefficient (C) and Initial Abstraction (IA)

Soil Symbol	FI				M								
Soil Series	Farmington				Muck								
Hydrologic Soils Group	B				B								
Soil Texture	Loam or Silt Loam				Muck								
Runoff Coefficient Type	2				2								
Area (ha)	9.00				7.00								
Percentage of Catchment	56%				44%								
Land Cover Category	IA	A (ha)	CN	C	A (ha)	CN	C	A (ha)	CN	C	A (ha)	CN	C
Impervious	2		100	0.95		100	0.95						
Gravel	3		89	0.27		89	0.27						
Woodland	10	6.08	60	0.25	7.00	60	0.25						
Pasture/Lawns	5	2.92	69	0.28		69	0.28						
Meadows	8		65	0.27		65	0.27						
Cultivated	7		74	0.35		74	0.35						
Waterbody	12		50	0.05		50	0.05						
Average CN	62.92				60.00								
Average C	0.26				0.25								
Average IA	8.38				10.00								

Time to Peak Calculations

Max. Catchment Elev. (m):	138.00
Min. Catchment Elev. (m):	134.00
Catchment Length (m):	738
Catchment Slope (%):	0.54%
Method: Airport Method	
Time of Concentration (mins):	91.55

Summary

Catchment CN:	61.6
Catchment C:	0.26
Catchment IA (mm):	9.09
Time of Concentration (hrs):	1.53
Catchment Time to Peak (hrs):	1.02
Catchment Time Step (mins):	12.21

Visual OTTHYMO Model Parameter Calculations (NasHYD)

Project Details

Project Number	522650
----------------	--------

Data Sources

Detailed Soil Survey Reports for Ontario, MTO Drainage Management Manual (1997)

Prepared By

Name	HY
------	----

Pre-Development Condition

Watershed:	N/A
Catchment ID:	201
Catchment Area (ha):	2.70
Impervious %:	5%

Average Curve Number (CN), Runoff Coefficient (C) and Initial Abstraction (IA)

Soil Symbol	FI				Os								
Soil Series	Farmington				Osgoode								
Hydrologic Soils Group	B				B								
Soil Texture	Loam or Silt Loam				Silt Loam								
Runoff Coefficient Type	2				2								
Area (ha)	0.40				2.30								
Percentage of Catchment	15%				85%								
Land Cover Category	IA	A (ha)	CN	C	A (ha)	CN	C	A (ha)	CN	C	A (ha)	CN	C
Impervious	2	0.02	100	0.95	0.12	100	0.95						
Gravel	3		89	0.27		89	0.27						
Woodland	10	0.12	60	0.25	0.18	60	0.25						
Pasture/Lawns	5	0.26	69	0.28	2.00	69	0.28						
Meadows	8		65	0.27		65	0.27						
Cultivated	7		74	0.35		74	0.35						
Waterbody	12		50	0.05		50	0.05						
Average CN	67.85				69.91								
Average C	0.30				0.31								
Average IA	6.35				5.23								

Time to Peak Calculations

Max. Catchment Elev. (m):	135.75
Min. Catchment Elev. (m):	133.00
Catchment Length (m):	225
Catchment Slope (%):	1.22%
Method: Airport Method	
Time of Concentration (mins):	36.09

Summary

Catchment CN:	69.6
Catchment C:	0.31
Catchment IA (mm):	5.40
Time of Concentration (hrs):	0.60
Catchment Time to Peak (hrs):	0.40
Catchment Time Step (mins):	4.81

Visual OTTHYMO Model Parameter Calculations (NasHYD)

Project Details

Project Number	522650
----------------	--------

Data Sources

Detailed Soil Survey Reports for Ontario, MTO Drainage Management Manual (1997)

Prepared By

Name	HY
------	----

Pre-Development Condition

Watershed:	N/A
Catchment ID:	202
Catchment Area (ha):	4.60
Impervious %:	15%

Average Curve Number (CN), Runoff Coefficient (C) and Initial Abstraction (IA)

Soil Symbol	FI				Os									
Soil Series	Farmington				Osgoode									
Hydrologic Soils Group	B				B									
Soil Texture	Loam or Silt Loam				Silt Loam									
Runoff Coefficient Type	2				2									
Area (ha)	3.72				0.88									
Percentage of Catchment	81%				19%									
Land Cover Category	IA	A (ha)	CN	C	A (ha)	CN	C	A (ha)	CN	C	A (ha)	CN	C	
Impervious	2	0.51	100	0.95	0.20	100	0.95							
Gravel	3		89	0.27		89	0.27							
Woodland	10	0.39	60	0.25		60	0.25							
Pasture/Lawns	5	2.81	69	0.28	0.68	69	0.28							
Meadows	8		65	0.27		65	0.27							
Cultivated	7		74	0.35		74	0.35							
Waterbody	12		50	0.05		50	0.05							
Average CN	72.30				76.03									
Average C	0.37				0.43									
Average IA	5.12				4.32									

Time to Peak Calculations

Max. Catchment Elev. (m):	137.88
Min. Catchment Elev. (m):	136.00
Catchment Length (m):	376
Catchment Slope (%):	0.50%
Method:	Airport Method
Time of Concentration (mins):	57.14

Summary

Catchment CN:	73.0
Catchment C:	0.38
Catchment IA (mm):	4.97
Time of Concentration (hrs):	0.95
Catchment Time to Peak (hrs):	0.63
Catchment Time Step (mins):	7.62

Visual OTTHYMO Model Parameter Calculations (NasHYD)

Project Details

Project Number	522650
----------------	--------

Data Sources

Detailed Soil Survey Reports for Ontario, MTO Drainage Management Manual (1997)

Prepared By

Name	HY
------	----

Pre-Development Condition

Watershed:	N/A
Catchment ID:	203
Catchment Area (ha):	11.00
Impervious %:	4%

Average Curve Number (CN), Runoff Coefficient (C) and Initial Abstraction (IA)

Soil Symbol	M				FI								
Soil Series	Muck				Farmington								
Hydrologic Soils Group	B				B								
Soil Texture	Muck				Loam or Silt Loam								
Runoff Coefficient Type	2				2								
Area (ha)	6.68				4.32								
Percentage of Catchment	61%				39%								
Land Cover Category	IA	A (ha)	CN	C	A (ha)	CN	C	A (ha)	CN	C	A (ha)	CN	C
Impervious	2	0.43	100	0.95		100	0.95						
Gravel	3		89	0.27		89	0.27						
Woodland	10	3.69	60	0.25	3.95	60	0.25						
Pasture/Lawns	5	2.56	69	0.28	0.37	69	0.28						
Meadows	8		65	0.27		65	0.27						
Cultivated	7		74	0.35		74	0.35						
Waterbody	12		50	0.05		50	0.05						
Average CN	66.04				60.77								
Average C	0.31				0.25								
Average IA	7.57				9.57								

Time to Peak Calculations

Max. Catchment Elev. (m):	137.15
Min. Catchment Elev. (m):	134.00
Catchment Length (m):	502.38
Catchment Slope (%):	0.63%
Method:	Airport Method
Time of Concentration (mins):	69.43

Summary

Catchment CN:	64.0
Catchment C:	0.29
Catchment IA (mm):	8.35
Time of Concentration (hrs):	1.16
Catchment Time to Peak (hrs):	0.77
Catchment Time Step (mins):	9.26

Visual OTTHYMO Model Parameter Calculations (NasHYD)

Project Details

Project Number	522650
----------------	--------

Data Sources

Detailed Soil Survey Reports for Ontario, MTO Drainage Management Manual (1997)

Prepared By

Name	HY
------	----

Pre-Development Condition

Watershed:	N/A
Catchment ID:	204
Catchment Area (ha):	3.90
Impervious %:	8%

Average Curve Number (CN), Runoff Coefficient (C) and Initial Abstraction (IA)

Soil Symbol	FI												
Soil Series	Farmington												
Hydrologic Soils Group	B												
Soil Texture	Loam or Silt Loam												
Runoff Coefficient Type	2												
Area (ha)	3.90												
Percentage of Catchment	100%												
Land Cover Category	IA	A (ha)	CN	C	A (ha)	CN	C	A (ha)	CN	C	A (ha)	CN	C
Impervious	2	0.33	100	0.95									
Gravel	3		89	0.27									
Woodland	10	2.07	60	0.25									
Pasture/Lawns	5	1.51	69	0.28									
Meadows	8		65	0.27									
Cultivated	7		74	0.35									
Waterbody	12		50	0.05									
Average CN	66.82												
Average C	0.32												
Average IA	7.40												

Time to Peak Calculations

Max. Catchment Elev. (m):	138.32
Min. Catchment Elev. (m):	136.15
Catchment Length (m):	102
Catchment Slope (%):	2.13%
Method:	Airport Method
Time of Concentration (mins):	20.02

Summary

Catchment CN:	66.8
Catchment C:	0.32
Catchment IA (mm):	7.40
Time of Concentration (hrs):	0.33
Catchment Time to Peak (hrs):	0.22
Catchment Time Step (mins):	2.67



Project :	Douglas Landing Subdivision
File No.	522650
Date:	Jan-25
Designed By:	HY
Checked By:	JA
Subject:	Impervious Area Calculations

Impervious Area Calculations

Soil type: F1	
201	Area (ha)
Asphalt	0.000
House	0.020
Driveway	0.00
Total Impervious Area (ha)	0.02
202	Area (ha)
Asphalt	0.330
House	0.100
Driveway	0.081
Total Impervious Area (ha)	0.51
203	Area (ha)
Asphalt	0.265
House	0.140
Driveway	0.03
Total Impervious Area (ha)	0.43
204	Area (ha)
Asphalt	0.192
House	0.080
Driveway	0.054
Total Impervious Area (ha)	0.33

Soil type: Os	
201	Area (ha)
Asphalt	0.000
House	0.12
Driveway	0.00
Total Impervious Area (0.12
202	Area (ha)
Asphalt	0.155
House	0.00
Driveway	0.05
Total Impervious Area (0.20
203	Area (ha)
Asphalt	0.000
House	0.00
Driveway	0.00
Total Impervious Area (0.00
204	Area (ha)
Asphalt	0.000
House	0.000
Driveway	0.000
Total Impervious Area (0.00

	Project :	Douglas Landing Subdivision
	File No.:	522650
	Date:	Jan-25
	Designed By:	HY
	Checked By:	JA
	Subject:	SWM Facility 1

Dry Pond Storage

Elevation	Depth	Increasing Area	Accum Area	Volume	Storage Volume ¹	Storage Volume ¹
(m)	(m)	(m ²)	(m ²)	(m ³)	(m ³)	(m ³)
133.65	0.00	0.00	2623.00	0.00	0.00	0.00
133.70	0.05	62.92	2685.92	132.72	132.72	132.72
133.75	0.10	63.66	2749.58	135.88	268.60	268.60
133.80	0.15	64.41	2813.99	139.09	407.69	407.69
133.85	0.20	65.15	2879.14	142.33	550.02	550.02
133.90	0.25	65.90	2945.04	145.60	695.62	695.62
133.95	0.30	66.64	3011.68	148.91	844.53	844.53
134.00	0.35	67.39	3079.07	152.27	996.80	996.80
134.05	0.40	68.14	3147.21	155.65	1152.45	1152.45
134.10	0.45	68.88	3216.09	159.08	1311.53	1311.53
134.15	0.50	69.63	3285.72	162.54	1474.07	1474.07
134.20	0.55	70.37	3356.09	166.04	1640.11	1640.11
134.25	0.60	71.12	3427.21	169.58	1809.69	1809.69
134.30	0.65	71.86	3499.07	173.15	1982.85	1982.85
134.35	0.70	72.61	3571.68	176.77	2159.61	2159.61
134.40	0.75	73.36	3645.04	180.41	2340.03	2340.03
134.45	0.80	74.10	3719.14	184.10	2524.13	2524.13
134.50	0.85	74.85	3793.99	187.83	2711.95	2711.95
134.55	0.90	75.59	3869.58	191.59	2903.54	2903.54
134.60	0.95	76.34	3945.92	195.38	3098.93	3098.93
134.65	1.00	77.08	4023.00	199.22	3298.14	3298.14

	Project :	Douglas Landing Subdivision
	File No.	522650
	Date:	Jan-25
	Designed By:	HY
	Checked By:	JA
Subject:	SWM Facility 2	

Dry Pond Storage

Elevation	Depth	Increasing Area	Accum Area	Volume	Storage Volume ¹
(m)	(m)	(m ²)	(m ²)	(m ³)	(m ³)
135.75	0.00	0.00	2796.00	0.00	0.00
135.80	0.05	50.30	2846.30	47.44	18.98
135.85	0.10	50.75	2897.05	143.58	76.41
135.90	0.15	51.20	2948.24	146.13	134.86
135.95	0.20	51.64	2999.89	148.70	194.34
136.00	0.25	52.09	3051.98	151.29	254.86
136.05	0.30	52.54	3104.52	153.91	316.42
136.10	0.35	52.99	3157.51	156.55	379.04
136.15	0.40	53.44	3210.95	159.21	442.73
136.20	0.45	53.89	3264.83	161.89	507.48
136.25	0.50	54.33	3319.17	164.60	573.32
136.30	0.55	54.78	3373.95	167.33	640.25
136.35	0.60	55.23	3429.18	170.08	708.28
136.40	0.65	55.68	3484.86	172.85	777.42
136.45	0.70	56.13	3540.99	175.64	847.68
136.50	0.75	56.58	3597.57	178.46	919.07
136.55	0.80	57.03	3654.59	181.30	991.59
136.60	0.85	57.47	3712.07	184.16	1065.25
136.65	0.90	57.92	3769.99	187.05	1140.07
136.70	0.95	58.37	3828.36	189.96	1216.06
136.75	1.00	58.82	3887.18	192.89	1293.21
136.80	1.05	59.27	3946.45	195.84	1371.55
136.85	1.10	59.72	4006.16	198.81	1451.07
136.90	1.15	60.16	4066.33	201.81	1531.80
136.95	1.20	60.61	4126.94	204.83	1613.73
137.00	1.25	61.06	4188.00	207.87	1696.88



Project: Douglas Landing Subdivision	Date: Jan-25
File No.: 522650	Designed: HY
Subject: Water Quality Calcs.	Checked: JA

Water quality Calculation (Catchment 202)

Swale Characteristics

Design Storms
25mm (m ³ /s)
0.023

<u>Channel Depth</u>	<u>Channel Type</u>	<u>Manning's N</u>	<u>Base Width</u>	<u>Side Slopes</u>	<u>Min. Slope</u>	<u>Total Area</u>	<u>Area Contributing</u>
1.00 m	Grass Ditch	0.035	0.50 m	3H : 1V	0.65%	4.600	0.410

Storm Conditions		Swale Flow Conditions					
Return Period	Peak Flow (m ³ /s)	Flow Depth	Area (m ²)	WP	R	Q (m ³ /s)	V (m/s)
25mm storm	0.004	0.034	0.02	0.72	0.03	0.004	0.22

Comments:

1. Area contributing is the max. sub drainage area contributing to a 0.5 m flat bottom grass swale within 202 (See Dwg. DP-2).
2. MTO pro-rating methodology for obtaining peak flow is as per the equation below.
3. V is lower than 0.5 m/s during the 25 mm storm.

$$Q = (1.00/n)AR^{2/3}S^{1/2}$$

Where Q = Peak Flow (m³)

n = Roughness Coefficient

A = Cross Sectional Area (m²)

R = Hydraulic Radius

S = Channel Slope (m/m)



Project: Douglas Landing Subdivision	Date: Jan-25
File No.: 522650	Designed: HY
Subject: Water Quality Calcs.	Checked: JA

Water quality Calculation (Catchment 203)

Swale Characteristics

Design Storms
25mm (m ³ /s)
0.020

<u>Channel Depth</u>	<u>Channel Type</u>	<u>Manning's N</u>	<u>Base Width</u>	<u>Side Slopes</u>	<u>Min. Slope</u>	<u>Total Area</u>	<u>Area Contributing</u>
1.00 m	Grass Ditch	0.035	0.50 m	3H : 1V	0.75%	3.900	0.060

Storm Conditions		Swale Flow Conditions					
Return Period	Peak Flow (m ³ /s)	Flow Depth	Area (m ²)	WP	R	Q (m ³ /s)	V (m/s)
25mm storm	0.001	0.010	0.01	0.56	0.01	0.001	0.11

- Comments:**
1. Area contributing is the max. sub drainage area contributing to a 0.5 m flat bottom grass swale within 203 (See Dwg. DP-2).
 2. MTO pro-rating methodology for obtaining peak flow is as per the equation below.
 3. V is lower than 0.5 m/s during the 25 mm storm.

$$Q = (1.00/n)AR^{2/3}S^{1/2}$$
 Where Q = Peak Flow (m³)
 n = Roughness Coefficient
 A = Cross Sectional Area (m²)
 R = Hydraulic Radius
 S = Channel Slope (m/m)



Project: Douglas Landing Subdivision	Date: Jan-25
File No.: 522650	Designed: HY
Subject: Ditch Capacity Calcs.	Checked: JA

Ditch Capacity Calculation (Catchment 202)

Swale Characteristics

Design Storms
100-Year Storm (m ³ /s)
0.296

<u>Channel Depth</u>	<u>Channel Type</u>	<u>Manning's N</u>	<u>Base Width</u>	<u>Side Slopes</u>	<u>Min. Slope</u>	<u>Total Area</u>	<u>Area Contributing</u>
1.00 m	Grass Ditch	0.035	0.50 m	3H : 1V	0.65%	4.600	0.410

Storm Conditions		Swale Flow Conditions					
Return Period	Peak Flow (m ³ /s)	Flow Depth	Area (m ²)	WP	R	Q (m ³ /s)	V (m/s)
100-Year storm	0.048	0.124	0.11	1.28	0.08	0.048	0.44

- Comments:**
1. Area contributing is the max. sub drainage area contributing to a 0.5 m flat bottom grass swale within 202 (See Dwg. DP-2).
 2. MTO pro-rating methodology for obtaining peak flow is as per the equation below.
 3. The 0.5 m flat-bottom road ditch has sufficient capacity to convey the 100-year storm at a depth of approximately 0.12 m.

$$Q = (1.00/n)AR^{2/3}S^{1/2}$$

Where Q = Peak Flow (m³)

- n = Roughness Coefficient
- A = Cross Sectional Area (m²)
- R = Hydraulic Radius
- S = Channel Slope (m/m)



Project: Douglas Landing Subdivision

Date: Jan-25

File No.: 522650

Designed By: HY

Subject: Dry SWM Pond Water Quality Calculations

Checked By: JA

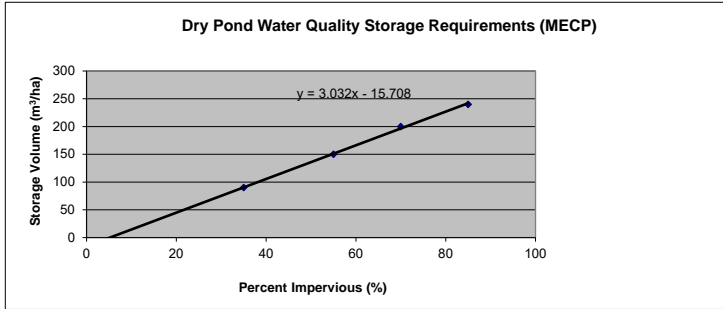

MECP Water Quality Storage Volumes

Table 3.2 Values

% imp	Storage (m³/ha)
35	90
55	150
70	200
85	240

(Basic 60% long-term TSS Removal)

SWMF 1 (Catchment 202)

Drainage Area (ha): 4.6
 % imp: 15.4%
 MECP Storage Volume Required (m³/ha): 31.1
 Water Quality Storage Requirement (m³): **143.2**
 25 mm Runoff Volume (m³): **161.9** (3.52 mm RV from Catchment 202 during a 25 mm storm)

As per the MECP manual, the larger of the 25 mm runoff volume erosion control active storage (162 m³) and the water quality active storage (143 m³) is to be detained a minimum of 24 hrs. As is recommended in the MECP manual, a detention time of 48 hours will be incorporated into the detailed design to improve suspended solids removal.

SWMF 2 (Catchment 204)

Drainage Area (ha): 3.9
 % imp: 8.4%
 MECP Storage Volume Required (m³/ha): 9.6
 Water Quality Storage Requirement (m³): **37.6**
 25 mm Runoff Volume (m³): **83.9** (2.15 mm RV from Catchment 205 during a 25 mm storm)

As per the MECP manual, the larger of the 25 mm runoff volume erosion control active storage (84 m³) and the water quality active storage (38 m³) is to be detained a minimum of 24 hrs. As is recommended in the MECP manual, a detention time of 48 hours will be incorporated into the detailed design to improve suspended solids removal.

PRE SCS

=====

```

V   V   I   SSSSS  U   U   A   L           (v 6.2.2015)
V   V   I   SS     U   U   A A  L
V   V   I   SS     U   U   AAAAA L
V   V   I   SS     U   U   A   A  L
  VV    I   SSSSS  UUUUU  A   A  LLLLL

```

```

  000  TTTTT  TTTTT  H   H  Y   Y  M   M  000  TM
  0   0   T    T    H   H  Y Y  MM MM  0   0
  0   0   T    T    H   H  Y   M   M  0   0
  000   T    T    H   H  Y   M   M  000

```

Developed and Distributed by Smart City Water Inc
 Copyright 2007 - 2022 Smart City Water Inc
 All rights reserved.

***** S U M M A R Y O U T P U T *****

Input filename: C:\Program Files (x86)\Visual OTTHYMO 6.2\V02\voin.dat

Output filename:

C:\Users\hyu\AppData\Local\Civica\XH5\e2c2d2be-418b-4c4d-a4c4-d228733f752c\b7c673a3-d93a-420f-bf9f-618013aa73aa\scenario

Summary filename:

C:\Users\hyu\AppData\Local\Civica\XH5\e2c2d2be-418b-4c4d-a4c4-d228733f752c\b7c673a3-d93a-420f-bf9f-618013aa73aa\scenario

DATE: 01/21/2025

TIME: 03:16:01

USER:

COMMENTS: _____

```

*****
** SIMULATION : Run 01           **
*****

```

W/E COMMAND	HYD ID	DT min	AREA ha	' Qpeak ' cms	Tpeak hrs	R.V. mm	R.C.	Qbase cms
-------------	--------	-----------	------------	------------------	--------------	------------	------	--------------

START @ 0.00 hrs

READ STORM 5.0

[Ptot= 49.09 mm]

fname :

C:\Users\hyu\AppData\Local\Temp\24654253-3d06-4df0-8958-96dec01b37b3\a83aa445-7986-4108-a295-abaadc5

remark: Ottawa Macdonald Cartier SCS 24 2yr

*

** CALIB NASHYD 0101 1 5.0 6.20 0.09 12.42 11.37 0.23 0.000

[CN=67.6]

[N = 3.0:Tp 0.48]

*

READ STORM 5.0

[Ptot= 49.09 mm]

fname :

C:\Users\hyu\AppData\Local\Temp\24654253-3d06-4df0-8958-96dec01b37b3\a83aa445-7986-4108-a295-abaadc5

remark: Ottawa Macdonald Cartier SCS 24 2yr

*

** CALIB NASHYD 0102 1 5.0 16.00 0.09 13.08 8.07 0.16 0.000

[CN=61.6]

[N = 3.0:Tp 1.02]

*

=====

V	V	I	SSSSS	U	U	A	L				(v 6.2.2015)
V	V	I	SS	U	U	A	A	L			
V	V	I	SS	U	U	AAAAA	L				
V	V	I	SS	U	U	A	A	L			
VV		I	SSSSS	UUUUU	A	A	LLLLL				

000	TTTTT	TTTTT	H	H	Y	Y	M	M	000	TM	
0	0	T	T	H	H	Y	Y	MM	MM	0	0
0	0	T	T	H	H	Y	M	M	0	0	
000	T	T	H	H	Y	M	M	000			

Developed and Distributed by Smart City Water Inc
Copyright 2007 - 2022 Smart City Water Inc
All rights reserved.

***** S U M M A R Y O U T P U T *****

Input filename: C:\Program Files (x86)\Visual OTTHYM0 6.2\V02\voin.dat

Output filename:

C:\Users\hyu\AppData\Local\Civica\H5\2c2d2be-418b-4c4d-a4c4-d228733f752c\48d72bde-

a8bc-439d-98b3-bdc48d81f7d4\scenario

Summary filename:

C:\Users\hyu\AppData\Local\Civica\XH5\2c2d2be-418b-4c4d-a4c4-d228733f752c\48d72bde-a8bc-439d-98b3-bdc48d81f7d4\scenario

DATE: 01/21/2025

TIME: 03:16:02

USER:

COMMENTS: _____

** SIMULATION : Run 02 **

W/E COMMAND	HYD ID	DT min	AREA ha	Qpeak cms	Tpeak hrs	R.V. mm	R.C.	Qbase cms
-------------	--------	-----------	------------	--------------	--------------	------------	------	--------------

START @ 0.00 hrs

READ STORM 5.0
[Ptot= 65.91 mm]
fname :

C:\Users\hyu\AppData\Local\Temp\24654253-3d06-4df0-8958-96dec01b37b3\5aca6ac2-ef25-4c6b-b023-6eea581

remark: Ottawa Macdonald Cartier SCS 24 5yr

*
** CALIB NASHYD 0101 1 5.0 6.20 0.16 12.33 19.88 0.30 0.000
[CN=67.6]
[N = 3.0:Tp 0.48]
*

READ STORM 5.0
[Ptot= 65.91 mm]
fname :

C:\Users\hyu\AppData\Local\Temp\24654253-3d06-4df0-8958-96dec01b37b3\5aca6ac2-ef25-4c6b-b023-6eea581

remark: Ottawa Macdonald Cartier SCS 24 5yr

*
** CALIB NASHYD 0102 1 5.0 16.00 0.18 13.08 15.01 0.23 0.000
[CN=61.6]
[N = 3.0:Tp 1.02]
*

=====
=====

```

V   V   I   SSSSS U   U   A   L           (v 6.2.2015)
V   V   I   SS    U   U   A A  L
V   V   I   SS    U   U   AAAAA L
V   V   I   SS    U   U   A   A  L
  WV    I   SSSSS UUUUU A   A  LLLLL

```

```

000  TTTTT  TTTTT  H   H  Y   Y  M   M  000  TM
0  0  T     T   H   H  Y  Y  MM  MM  0  0
0  0  T     T   H   H  Y   M   M  0  0
000  T     T   H   H  Y   M   M  000

```

Developed and Distributed by Smart City Water Inc
 Copyright 2007 - 2022 Smart City Water Inc
 All rights reserved.

***** S U M M A R Y O U T P U T *****

Input filename: C:\Program Files (x86)\Visual OTTHYMO 6.2\V02\voin.dat

Output filename:

C:\Users\hyu\AppData\Local\Civica\XH5\e2c2d2be-418b-4c4d-a4c4-d228733f752c\1ace527b-71f6-4947-8e0b-cd91c17f66d9\scenario

Summary filename:

C:\Users\hyu\AppData\Local\Civica\XH5\e2c2d2be-418b-4c4d-a4c4-d228733f752c\1ace527b-71f6-4947-8e0b-cd91c17f66d9\scenario

DATE: 01/21/2025

TIME: 03:16:01

USER:

COMMENTS: _____

```

*****
** SIMULATION : Run 03          **
*****

```

W/E COMMAND	HYD ID	DT min	AREA ha	Qpeak cms	Tpeak hrs	R.V. mm	R.C.	Qbase cms
-------------	--------	-----------	------------	--------------	--------------	------------	------	--------------

START @ 0.00 hrs

```

-----
READ STORM          5.0
[ Ptot= 77.00 mm ]
fname :

```

C:\Users\hyu\AppData\Local\Temp\24654253-3d06-4df0-8958-96dec01b37b3\937e7433-4342-4

0da-96a5-67c3cdf
remark: Ottawa Macdonald Cartier SCS 24 10yr

*
** CALIB NASHYD 0101 1 5.0 6.20 0.22 12.33 26.29 0.34 0.000
[CN=67.6]
[N = 3.0:Tp 0.48]

*
READ STORM 5.0
[Ptot= 77.00 mm]
fname :

C:\Users\hyu\AppData\Local\Temp\24654253-3d06-4df0-8958-96dec01b37b3\937e7433-4342-4
0da-96a5-67c3cdf
remark: Ottawa Macdonald Cartier SCS 24 10yr

*
** CALIB NASHYD 0102 1 5.0 16.00 0.25 13.00 20.38 0.26 0.000
[CN=61.6]
[N = 3.0:Tp 1.02]

=====
=====

V V I SSSSS U U A L (v 6.2.2015)
V V I SS U U A A L
V V I SS U U AAAAA L
V V I SS U U A A L
VV I SSSSS UUUUU A A LLLLL

000 TTTTT TTTTT H H Y Y M M 000 TM
0 0 T T H H Y Y MM MM 0 0
0 0 T T H H Y M M 0 0
000 T T H H Y M M 000

Developed and Distributed by Smart City Water Inc
Copyright 2007 - 2022 Smart City Water Inc
All rights reserved.

***** S U M M A R Y O U T P U T *****

Input filename: C:\Program Files (x86)\Visual OTTHYMO 6.2\V02\voin.dat

Output filename:

C:\Users\hyu\AppData\Local\Civica\H5\2c2d2be-418b-4c4d-a4c4-d228733f752c\6243bf8c-4ae0-4a08-a8e3-f49e4486c92a\scenario

Summary filename:

C:\Users\hyu\AppData\Local\Civica\H5\2c2d2be-418b-4c4d-a4c4-d228733f752c\6243bf8c-4ae0-4a08-a8e3-f49e4486c92a\scenario

DATE: 01/21/2025

TIME: 03:16:02

USER:

COMMENTS: _____

** SIMULATION : Run 04 **

W/E COMMAND	HYD ID	DT min	AREA ha	Qpeak cms	Tpeak hrs	R.V. mm	R.C.	Qbase cms
-------------	--------	-----------	------------	--------------	--------------	------------	------	--------------

START @ 0.00 hrs

READ STORM 5.0

[Ptot= 91.08 mm]

fname :

C:\Users\hyu\AppData\Local\Temp\24654253-3d06-4df0-8958-96dec01b37b3\8677e260-0877-4303-925b-23f8544

remark: Ottawa Macdonald Cartier SCS 24 25yr

*

** CALIB NASHYD 0101 1 5.0 6.20 0.29 12.33 35.15 0.39 0.000

[CN=67.6]

[N = 3.0:Tp 0.48]

*

READ STORM 5.0

[Ptot= 91.08 mm]

fname :

C:\Users\hyu\AppData\Local\Temp\24654253-3d06-4df0-8958-96dec01b37b3\8677e260-0877-4303-925b-23f8544

remark: Ottawa Macdonald Cartier SCS 24 25yr

*

** CALIB NASHYD 0102 1 5.0 16.00 0.34 13.00 27.97 0.31 0.000

[CN=61.6]

[N = 3.0:Tp 1.02]

*

FINISH

=====
=====

=====
=====

```

V   V   I   SSSSS  U   U   A   L           (v 6.2.2015)
V   V   I   SS     U   U   A A  L
V   V   I   SS     U   U   AAAAA L
V   V   I   SS     U   U   A   A  L
  W    I   SSSSS  UUUUU  A   A  LLLLL

```

```

000  TTTTT  TTTTT  H   H  Y   Y  M   M  000  TM
0   0   T    T    H   H  Y Y  MM MM  0   0
0   0   T    T    H   H  Y   M   M  0   0
000  T    T    H   H  Y   M   M  000

```

Developed and Distributed by Smart City Water Inc
 Copyright 2007 - 2022 Smart City Water Inc
 All rights reserved.

***** S U M M A R Y O U T P U T *****

Input filename: C:\Program Files (x86)\Visual OTTHYMO 6.2\V02\voin.dat

Output filename:

C:\Users\hyu\AppData\Local\Civica\XH5\e2c2d2be-418b-4c4d-a4c4-d228733f752c\3bbd3ed3-0f4e-4017-afe6-9df0a6e75feb\scenario

Summary filename:

C:\Users\hyu\AppData\Local\Civica\XH5\e2c2d2be-418b-4c4d-a4c4-d228733f752c\3bbd3ed3-0f4e-4017-afe6-9df0a6e75feb\scenario

DATE: 01/21/2025

TIME: 03:16:02

USER:

COMMENTS: _____

```

*****
** SIMULATION : Run 05           **
*****

```

W/E COMMAND	HYD ID	DT min	AREA ha	Qpeak cms	Tpeak hrs	R.V. mm	R.C.	Qbase cms
-------------	--------	-----------	------------	--------------	--------------	------------	------	--------------

START @ 0.00 hrs

READ STORM		5.0						
------------	--	-----	--	--	--	--	--	--

[Ptot=101.52 mm]

fname :

C:\Users\hyu\AppData\Local\Temp\24654253-3d06-4df0-8958-96dec01b37b3\55c88cf1-c07d-4de2-b4c7-fa9ea96

remark: Ottawa Macdonald Cartier SCS 24 50yr

*

** CALIB NASHYD 0101 1 5.0 6.20 0.35 12.33 42.15 0.42 0.000
[CN=67.6]
[N = 3.0:Tp 0.48]

*

READ STORM 5.0
[Ptot=101.52 mm]
fname :

C:\Users\hyu\AppData\Local\Temp\24654253-3d06-4df0-8958-96dec01b37b3\55c88cf1-c07d-4de2-b4c7-fa9ea96

remark: Ottawa Macdonald Cartier SCS 24 50yr

*

** CALIB NASHYD 0102 1 5.0 16.00 0.42 13.00 34.07 0.34 0.000
[CN=61.6]
[N = 3.0:Tp 1.02]

*

=====
=====

V V I SSSSS U U A L (v 6.2.2015)
V V I SS U U A A L
V V I SS U U AAAAA L
V V I SS U U A A L
VV I SSSSS UUUUU A A LLLLL

000 TTTTT TTTTT H H Y Y M M 000 TM
O O T T H H Y Y MM MM O O
O O T T H H Y M M O O
000 T T H H Y M M 000

Developed and Distributed by Smart City Water Inc
Copyright 2007 - 2022 Smart City Water Inc
All rights reserved.

***** S U M M A R Y O U T P U T *****

Input filename: C:\Program Files (x86)\Visual OTTHYMO 6.2\V02\voin.dat

Output filename:

C:\Users\hyu\AppData\Local\Civica\XH5\e2c2d2be-418b-4c4d-a4c4-d228733f752c\55b99d40-0c8b-47be-9fa6-dc2d5ea4e01b\scenario

Summary filename:

C:\Users\hyu\AppData\Local\Civica\XH5\e2c2d2be-418b-4c4d-a4c4-d228733f752c\55b99d40-

0c8b-47be-9fa6-dc2d5ea4e01b\scenario

DATE: 01/21/2025

TIME: 03:16:02

USER:

COMMENTS: _____

** SIMULATION : Run 06 **

W/E COMMAND	HYD ID	DT min	AREA ha	Qpeak cms	Tpeak hrs	R.V. mm	R.C.	Qbase cms
-------------	--------	-----------	------------	--------------	--------------	------------	------	--------------

START @ 0.00 hrs

READ STORM 5.0

[Ptot=111.87 mm]

fname :

C:\Users\hyu\AppData\Local\Temp\24654253-3d06-4df0-8958-96dec01b37b3\20e7578-d439-4ffb-8edc-8fe2588

remark: Ottawa Macdonald Cartier SCS 24 100yr

*

** CALIB NASHYD 0101 1 5.0 6.20 0.42 12.33 49.41 0.44 0.000

[CN=67.6]

[N = 3.0:Tp 0.48]

*

READ STORM 5.0

[Ptot=111.87 mm]

fname :

C:\Users\hyu\AppData\Local\Temp\24654253-3d06-4df0-8958-96dec01b37b3\20e7578-d439-4ffb-8edc-8fe2588

remark: Ottawa Macdonald Cartier SCS 24 100yr

*

** CALIB NASHYD 0102 1 5.0 16.00 0.50 13.00 40.46 0.36 0.000

[CN=61.6]

[N = 3.0:Tp 1.02]

*

PRE 3HR CHI

=====

```

V   V   I   SSSSS  U   U   A   L           (v 6.2.2015)
V   V   I   SS     U   U   A A  L
V   V   I   SS     U   U   AAAAA L
V   V   I   SS     U   U   A   A  L
  VV    I   SSSSS  UUUUU  A   A  LLLLL

```

```

  000  TTTTT  TTTTT  H   H  Y   Y  M   M  000  TM
  0   0   T    T    H   H  Y Y  MM MM  0   0
  0   0   T    T    H   H  Y   M   M  0   0
  000   T    T    H   H  Y   M   M  000

```

Developed and Distributed by Smart City Water Inc
 Copyright 2007 - 2022 Smart City Water Inc
 All rights reserved.

***** S U M M A R Y O U T P U T *****

Input filename: C:\Program Files (x86)\Visual OTTHYMO 6.2\V02\voin.dat

Output filename:

C:\Users\hyu\AppData\Local\Civica\XH5\e2c2d2be-418b-4c4d-a4c4-d228733f752c\e28cf0ce-79f6-480b-b26a-9525c4486966\scenario

Summary filename:

C:\Users\hyu\AppData\Local\Civica\XH5\e2c2d2be-418b-4c4d-a4c4-d228733f752c\e28cf0ce-79f6-480b-b26a-9525c4486966\scenario

DATE: 01/21/2025

TIME: 03:16:58

USER:

COMMENTS: _____

```

*****
** SIMULATION : 1 **
*****

```

W/E COMMAND	HYD ID	DT min	AREA ha	' Qpeak ' cms	Tpeak hrs	R.V. mm	R.C.	Qbase cms
-------------	--------	-----------	------------	------------------	--------------	------------	------	--------------

START @ 0.00 hrs

READ STORM 10.0

[Ptot= 25.00 mm]

fname :

C:\Users\hyu\AppData\Local\Temp\15823490-94f4-4a1a-981e-c0944b0b6988\ed1aeef3-57d0-4944-a888-6b10dc9

remark: 25MM4HR

*

** CALIB NASHYD 0102 1 5.0 16.00 0.02 2.92 1.45 0.06 0.000

[CN=61.6]

[N = 3.0:Tp 1.02]

*

READ STORM 10.0

[Ptot= 25.00 mm]

fname :

C:\Users\hyu\AppData\Local\Temp\15823490-94f4-4a1a-981e-c0944b0b6988\ed1aeef3-57d0-4944-a888-6b10dc9

remark: 25MM4HR

*

** CALIB NASHYD 0101 1 5.0 6.20 0.03 2.00 2.62 0.10 0.000

[CN=67.6]

[N = 3.0:Tp 0.48]

*

=====

V	V	I	SSSSS	U	U	A	L				(v 6.2.2015)
V	V	I	SS	U	U	A	A	L			
V	V	I	SS	U	U	AAAAA	L				
V	V	I	SS	U	U	A	A	L			
VV		I	SSSSS	UUUUU	A	A	LLLLL				

000	TTTTT	TTTTT	H	H	Y	Y	M	M	000	TM	
0	0	T	T	H	H	Y	Y	MM	MM	0	0
0	0	T	T	H	H	Y	M	M	0	0	
000	T	T	H	H	Y	M	M	000			

Developed and Distributed by Smart City Water Inc
Copyright 2007 - 2022 Smart City Water Inc
All rights reserved.

***** S U M M A R Y O U T P U T *****

Input filename: C:\Program Files (x86)\Visual OTTHYM0 6.2\V02\voin.dat

Output filename:

C:\Users\hyu\AppData\Local\Civica\H5\2c2d2be-418b-4c4d-a4c4-d228733f752c\c7f97b19-

9fba-4182-bf5a-325b733b6df3\scenario

Summary filename:

C:\Users\hyu\AppData\Local\Civica\XH5\e2c2d2be-418b-4c4d-a4c4-d228733f752c\c7f97b19-9fba-4182-bf5a-325b733b6df3\scenario

DATE: 01/21/2025

TIME: 03:16:58

USER:

COMMENTS: _____

** SIMULATION : 2 **

W/E COMMAND	HYD ID	DT min	AREA ha	Qpeak cms	Tpeak hrs	R.V. mm	R.C.	Qbase cms
-------------	--------	-----------	------------	--------------	--------------	------------	------	--------------

START @ 0.00 hrs

CHIC STORM 10.0
[Ptot= 31.86 mm]

** CALIB NASHYD	0102	1	5.0	16.00	0.05	2.50	2.86	0.09	0.000
[CN=61.6]									
[N = 3.0:Tp 1.02]									

CHIC STORM 10.0
[Ptot= 31.86 mm]

** CALIB NASHYD	0101	1	5.0	6.20	0.05	1.67	4.60	0.14	0.000
[CN=67.6]									
[N = 3.0:Tp 0.48]									

=====

```

V  V  I  SSSSS  U  U  A  L          (v 6.2.2015)
V  V  I  SS    U  U  A  A  L
V  V  I  SS    U  U  AAAAA  L
V  V  I  SS    U  U  A  A  L
  VV  I  SSSSS  UUUUU  A  A  LLLLL

```

```

000  TTTT  TTTT  H  H  Y  Y  M  M  000  TM
0  0  T  T  H  H  Y  Y  MM  MM  0  0
0  0  T  T  H  H  Y  Y  M  M  0  0

```

000 T T H H Y M M 000
 Developed and Distributed by Smart City Water Inc
 Copyright 2007 - 2022 Smart City Water Inc
 All rights reserved.

***** S U M M A R Y O U T P U T *****

Input filename: C:\Program Files (x86)\Visual OTTHYMO 6.2\V02\voin.dat

Output filename:

C:\Users\hyu\AppData\Local\Civica\XH5\e2c2d2be-418b-4c4d-a4c4-d228733f752c\b58e0786-09b1-422c-89b1-93d8b6a845b0\scenario

Summary filename:

C:\Users\hyu\AppData\Local\Civica\XH5\e2c2d2be-418b-4c4d-a4c4-d228733f752c\b58e0786-09b1-422c-89b1-93d8b6a845b0\scenario

DATE: 01/21/2025

TIME: 03:16:58

USER:

COMMENTS: _____

 ** SIMULATION : 3 **

W/E COMMAND	HYD ID	DT min	AREA ha	Qpeak cms	Tpeak hrs	R.V. mm	R.C.	Qbase cms
-------------	--------	-----------	------------	--------------	--------------	------------	------	--------------

START @ 0.00 hrs

 CHIC STORM 10.0
 [Ptot= 42.51 mm]

*
 ** CALIB NASHYD 0102 1 5.0 16.00 0.10 2.42 5.83 0.14 0.000
 [CN=61.6]
 [N = 3.0:Tp 1.02]

*
 CHIC STORM 10.0
 [Ptot= 42.51 mm]

*
 ** CALIB NASHYD 0101 1 5.0 6.20 0.10 1.58 8.52 0.20 0.000
 [CN=67.6]
 [N = 3.0:Tp 0.48]

*

=====

V V I SSSSS U U A L (v 6.2.2015)
V V I SS U U A A L
V V I SS U U AAAAA L
V V I SS U U A A L
VV I SSSSS UUUUU A A LLLLL

000 TTTTT TTTTT H H Y Y M M 000 TM
O O T T H H Y Y MM MM O O
O O T T H H Y M M O O
000 T T H H Y M M 000

Developed and Distributed by Smart City Water Inc
Copyright 2007 - 2022 Smart City Water Inc
All rights reserved.

***** S U M M A R Y O U T P U T *****

Input filename: C:\Program Files (x86)\Visual OTTHYMO 6.2\V02\voin.dat

Output filename:

C:\Users\hyu\AppData\Local\Civica\XH5\e2c2d2be-418b-4c4d-a4c4-d228733f752c\28e76a64-8791-4902-91a8-45de48590b12\scenario

Summary filename:

C:\Users\hyu\AppData\Local\Civica\XH5\e2c2d2be-418b-4c4d-a4c4-d228733f752c\28e76a64-8791-4902-91a8-45de48590b12\scenario

DATE: 01/21/2025

TIME: 03:16:58

USER:

COMMENTS: _____

** SIMULATION : 4 **

W/E COMMAND HYD ID DT AREA ' Qpeak Tpeak R.V. R.C. Qbase
min ha ' cms hrs mm cms

START @ 0.00 hrs

CHIC STORM 10.0

```

    [ Ptot= 49.50 mm ]
*
** CALIB NASHYD          0102  1  5.0   16.00   0.15  2.42   8.22  0.17   0.000
   [CN=61.6              ]
   [ N = 3.0:Tp 1.02]
*
   CHIC STORM              10.0
   [ Ptot= 49.50 mm ]
*
** CALIB NASHYD          0101  1  5.0    6.20   0.14  1.58  11.56  0.23   0.000
   [CN=67.6              ]
   [ N = 3.0:Tp 0.48]
*

```

```

=====
=====

```

```

V  V  I  SSSSS  U  U  A  L          (v 6.2.2015)
V  V  I  SS    U  U  A  A  L
V  V  I  SS    U  U  AAAAA  L
V  V  I  SS    U  U  A  A  L
  WV  I  SSSSS  UUUUU  A  A  LLLLL

```

```

000  TTTTT  TTTTT  H  H  Y  Y  M  M  000  TM
0  0  T  T  H  H  Y  Y  MM  MM  0  0
0  0  T  T  H  H  Y  M  M  0  0
000  T  T  H  H  Y  M  M  000

```

Developed and Distributed by Smart City Water Inc
 Copyright 2007 - 2022 Smart City Water Inc
 All rights reserved.

***** S U M M A R Y O U T P U T *****

Input filename: C:\Program Files (x86)\Visual OTTHYMO 6.2\V02\voin.dat

Output filename:
 C:\Users\hyu\AppData\Local\Civica\XH5\e2c2d2be-418b-4c4d-a4c4-d228733f752c\6bdac20-58ac-4ee3-9aca-0f7f77a124fb\scenario
 Summary filename:
 C:\Users\hyu\AppData\Local\Civica\XH5\e2c2d2be-418b-4c4d-a4c4-d228733f752c\6bdac20-58ac-4ee3-9aca-0f7f77a124fb\scenario

DATE: 01/21/2025

TIME: 03:16:58

USER:

COMMENTS: _____

** SIMULATION : 5 **

W/E COMMAND	HYD ID	DT min	AREA ha	Qpeak cms	Tpeak hrs	R.V. mm	R.C.	Qbase cms
-------------	--------	--------	---------	-----------	-----------	---------	------	-----------

START @ 0.00 hrs

CHIC STORM 10.0
[Ptot= 58.23 mm]

*	** CALIB NASHYD	0102	1	5.0	16.00	0.21	2.33	11.64	0.20	0.000
	[CN=61.6									
	[N = 3.0:Tp 1.02]									

*	CHIC STORM				10.0					
	[Ptot= 58.23 mm]									
*	** CALIB NASHYD	0101	1	5.0	6.20	0.19	1.58	15.80	0.27	0.000
	[CN=67.6									
	[N = 3.0:Tp 0.48]									

FINISH

```
=====
=====
=====
=====
```

V	V	I	SSSSS	U	U	A	L				(v 6.2.2015)
V	V	I	SS	U	U	A	A	L			
V	V	I	SS	U	U	AAAAA	L				
V	V	I	SS	U	U	A	A	L			
VV		I	SSSSS	UUUUU	A	A	LLLLL				

000	TTTTT	TTTTT	H	H	Y	Y	M	M	000	TM	
0	0	T	T	H	H	Y	Y	MM	MM	0	0
0	0	T	T	H	H	Y	M	M	0	0	
000	T	T	H	H	Y	M	M	000			

Developed and Distributed by Smart City Water Inc
Copyright 2007 - 2022 Smart City Water Inc
All rights reserved.

***** S U M M A R Y O U T P U T *****

Input filename: C:\Program Files (x86)\Visual OTTHYM0 6.2\V02\voin.dat

Output filename:

C:\Users\hyu\AppData\Local\Civica\XH5\e2c2d2be-418b-4c4d-a4c4-d228733f752c\bf07d2df-2c0e-4d2f-8c07-9a40dd6cc688\scenario

Summary filename:

C:\Users\hyu\AppData\Local\Civica\XH5\e2c2d2be-418b-4c4d-a4c4-d228733f752c\bf07d2df-2c0e-4d2f-8c07-9a40dd6cc688\scenario

DATE: 01/21/2025

TIME: 03:16:58

USER:

COMMENTS: _____

 ** SIMULATION : 6 **

W/E COMMAND	HYD ID	DT	AREA	Qpeak	Tpeak	R.V.	R.C.	Qbase
		min	ha	cms	hrs	mm		cms

START @ 0.00 hrs

 CHIC STORM 10.0
 [Ptot= 64.81 mm]

* ** CALIB NASHYD	0102	1	5.0	16.00	0.26	2.33	14.50	0.22	0.000
[CN=61.6]									
[N = 3.0:Tp 1.02]									

* CHIC STORM 10.0
 [Ptot= 64.81 mm]

* ** CALIB NASHYD	0101	1	5.0	6.20	0.23	1.58	19.28	0.30	0.000
[CN=67.6]									
[N = 3.0:Tp 0.48]									

=====
 =====

V V I SSSSS U U A L (v 6.2.2015)
 V V I SS U U A A L

```
V V I SS U U AAAAA L
V V I SS U U A A L
VV I SSSSS UUUUU A A LLLLL
```

```
000 TTTTT TTTTT H H Y Y M M 000 TM
0 0 T T H H Y Y MM MM 0 0
0 0 T T H H Y M M 0 0
000 T T H H Y M M 000
```

Developed and Distributed by Smart City Water Inc
 Copyright 2007 - 2022 Smart City Water Inc
 All rights reserved.

***** S U M M A R Y O U T P U T *****

Input filename: C:\Program Files (x86)\Visual OTTHYMO 6.2\V02\voin.dat

Output filename:

C:\Users\hyu\AppData\Local\Civica\H5\e2c2d2be-418b-4c4d-a4c4-d228733f752c\7ee998aa-5e81-4e30-8c5a-3486e39ec25b\scenario

Summary filename:

C:\Users\hyu\AppData\Local\Civica\H5\e2c2d2be-418b-4c4d-a4c4-d228733f752c\7ee998aa-5e81-4e30-8c5a-3486e39ec25b\scenario

DATE: 01/21/2025

TIME: 03:16:58

USER:

COMMENTS: _____

```
*****
** SIMULATION : 7 **
*****
```

W/E COMMAND	HYD ID	DT	AREA	Qpeak	Tpeak	R.V.	R.C.	Qbase
		min	ha	cms	hrs	mm		cms

START @ 0.00 hrs

 CHIC STORM 10.0
 [Ptot= 71.66 mm]

*

** CALIB NASHYD	0102	1	5.0	16.00	0.32	2.33	17.72	0.25	0.000
[CN=61.6									
[N = 3.0:Tp 1.02]									

*

CHIC STORM
[Ptot= 71.66 mm]

10.0

*

** CALIB NASHYD 0101 1 5.0 6.20 0.28 1.58 23.14 0.32 0.000
[CN=67.6]
[N = 3.0:Tp 0.48]

*

PRE 6HR CHI

=====

```

V   V   I   SSSSS  U   U   A   L           (v 6.2.2015)
V   V   I   SS     U   U   A A  L
V   V   I   SS     U   U   AAAAA L
V   V   I   SS     U   U   A   A  L
  VV    I   SSSSS  UUUUU  A   A  LLLLL

```

```

  000  TTTTT  TTTTT  H   H  Y   Y  M   M   000  TM
  0   0   T    T    H   H   Y Y  MM MM  0   0
  0   0   T    T    H   H   Y   M   M  0   0
  000   T    T    H   H   Y   M   M  000

```

Developed and Distributed by Smart City Water Inc
 Copyright 2007 - 2022 Smart City Water Inc
 All rights reserved.

***** S U M M A R Y O U T P U T *****

Input filename: C:\Program Files (x86)\Visual OTTHYMO 6.2\V02\voin.dat

Output filename:

C:\Users\hyu\AppData\Local\Civica\VH5\e2c2d2be-418b-4c4d-a4c4-d228733f752c\cfce4adb-9358-4398-838c-cb02694b2e16\scenario

Summary filename:

C:\Users\hyu\AppData\Local\Civica\VH5\e2c2d2be-418b-4c4d-a4c4-d228733f752c\cfce4adb-9358-4398-838c-cb02694b2e16\scenario

DATE: 01/21/2025

TIME: 03:17:44

USER:

COMMENTS: _____

```

*****
** SIMULATION : 1 **
*****

```

W/E COMMAND	HYD ID	DT min	AREA ha	' Qpeak ' cms	Tpeak hrs	R.V. mm	R.C.	Qbase cms
-------------	--------	-----------	------------	------------------	--------------	------------	------	--------------

START @ 0.00 hrs

```

CHIC STORM                10.0
[ Ptot= 36.86 mm ]
*
** CALIB NASHYD           0102  1  5.0  16.00   0.06  3.42  4.14  0.11  0.000
[CN=61.6                   ]
[ N = 3.0:Tp 1.02]
*
CHIC STORM                10.0
[ Ptot= 36.86 mm ]
*
** CALIB NASHYD           0101  1  5.0   6.20   0.06  2.58  6.32  0.17  0.000
[CN=67.6                   ]
[ N = 3.0:Tp 0.48]
*
FINISH

```

```

=====
=====
=====
=====

```

```

V  V  I  SSSSS  U  U  A  L                (v 6.2.2015)
V  V  I  SS    U  U  A  A  L
V  V  I  SS    U  U  AAAAA  L
V  V  I  SS    U  U  A  A  L
  W   I  SSSSS  UUUUU  A  A  LLLLL
000  TTTTT  TTTTT  H  H  Y  Y  M  M  000  TM
0  0  T  T  H  H  Y  Y  MM  MM  0  0
0  0  T  T  H  H  Y  M  M  0  0
000  T  T  H  H  Y  M  M  000

```

Developed and Distributed by Smart City Water Inc
 Copyright 2007 - 2022 Smart City Water Inc
 All rights reserved.

***** S U M M A R Y O U T P U T *****

Input filename: C:\Program Files (x86)\Visual OTTHYMO 6.2\V02\voin.dat

Output filename:

C:\Users\hyu\AppData\Local\Civica\XH5\e2c2d2be-418b-4c4d-a4c4-d228733f752c\5684a8ab-2c05-487a-95a1-fdcc817e2254\scenario

Summary filename:

C:\Users\hyu\AppData\Local\Civica\XH5\e2c2d2be-418b-4c4d-a4c4-d228733f752c\5684a8ab-2c05-487a-95a1-fdcc817e2254\scenario

DATE: 01/21/2025

TIME: 03:17:44

USER:

COMMENTS: _____

** SIMULATION : 2 **

W/E COMMAND	HYD ID	DT min	AREA ha	Qpeak cms	Tpeak hrs	R.V. mm	R.C.	Qbase cms
-------------	--------	-----------	------------	--------------	--------------	------------	------	--------------

START @ 0.00 hrs

CHIC STORM 10.0
[Ptot= 49.04 mm]

*	** CALIB NASHYD	0102	1	5.0	16.00	0.12	3.33	8.05	0.16	0.000
	[CN=61.6									
	[N = 3.0:Tp 1.02]									

*
CHIC STORM 10.0
[Ptot= 49.04 mm]

*	** CALIB NASHYD	0101	1	5.0	6.20	0.11	2.58	11.34	0.23	0.000
	[CN=67.6									
	[N = 3.0:Tp 0.48]									

=====
=====

V	V	I	SSSSS	U	U	A	L				(v 6.2.2015)
V	V	I	SS	U	U	A	A	L			
V	V	I	SS	U	U	AAAAA	L				
V	V	I	SS	U	U	A	A	L			
VV	I	SSSSS	UUUUU	A	A	LLLLL					

000	TTTTT	TTTTT	H	H	Y	Y	M	M	000	TM	
0	0	T	T	H	H	Y	Y	MM	MM	0	0
0	0	T	T	H	H	Y	M	M	0	0	
000	T	T	H	H	Y	M	M	000			

Developed and Distributed by Smart City Water Inc
Copyright 2007 - 2022 Smart City Water Inc
All rights reserved.

***** S U M M A R Y O U T P U T *****

Input filename: C:\Program Files (x86)\Visual OTTHYMO 6.2\V02\voin.dat

Output filename:

C:\Users\hyu\AppData\Local\Civica\XH5\e2c2d2be-418b-4c4d-a4c4-d228733f752c\a138721b-88bd-4564-8dec-735abe8ef836\scenario

Summary filename:

C:\Users\hyu\AppData\Local\Civica\XH5\e2c2d2be-418b-4c4d-a4c4-d228733f752c\a138721b-88bd-4564-8dec-735abe8ef836\scenario

DATE: 01/21/2025

TIME: 03:17:44

USER:

COMMENTS: _____

** SIMULATION : 3 **

W/E COMMAND	HYD ID	DT	AREA	Qpeak	Tpeak	R.V.	R.C.	Qbase
		min	ha	cms	hrs	mm		cms

START @ 0.00 hrs

CHIC STORM 10.0
[Ptot= 57.02 mm]

*
** CALIB NASHYD 0102 1 5.0 16.00 0.16 3.33 11.14 0.20 0.000
[CN=61.6]
[N = 3.0:Tp 1.02]

*
CHIC STORM 10.0
[Ptot= 57.02 mm]

*
** CALIB NASHYD 0101 1 5.0 6.20 0.15 2.58 15.18 0.27 0.000
[CN=67.6]
[N = 3.0:Tp 0.48]

=====
=====

```

*
  CHIC STORM                10.0
  [ Ptot= 66.93 mm ]
*
** CALIB NASHYD            0101  1  5.0   6.20   0.21  2.58  20.45  0.31   0.000
  [CN=67.6                ]
  [ N = 3.0:Tp 0.48]
*
=====
=====

```

```

  V  V  I  SSSSS  U  U  A  L              (v 6.2.2015)
  V  V  I  SS    U  U  A  A  L
  V  V  I  SS    U  U  AAAAA  L
  V  V  I  SS    U  U  A  A  L
    VV  I  SSSSS  UUUUU  A  A  LLLLL
      000  TTTT  TTTT  H  H  Y  Y  M  M  000  TM
      0  0  T  T  H  H  Y  Y  MM  MM  0  0
      0  0  T  T  H  H  Y  M  M  0  0
      000  T  T  H  H  Y  M  M  000

```

Developed and Distributed by Smart City Water Inc
 Copyright 2007 - 2022 Smart City Water Inc
 All rights reserved.

***** S U M M A R Y O U T P U T *****

Input filename: C:\Program Files (x86)\Visual OTTHYMO 6.2\V02\voin.dat

Output filename:
 C:\Users\hyu\AppData\Local\Civica\XH5\e2c2d2be-418b-4c4d-a4c4-d228733f752c\61f54fa0-60a2-4bf7-8608-fb015652c505\scenario
 Summary filename:
 C:\Users\hyu\AppData\Local\Civica\XH5\e2c2d2be-418b-4c4d-a4c4-d228733f752c\61f54fa0-60a2-4bf7-8608-fb015652c505\scenario

DATE: 01/21/2025 TIME: 03:17:44

USER:

COMMENTS: _____

```

*****
** SIMULATION : 5              **

```

W/E COMMAND	HYD ID	DT min	AREA ha	Qpeak cms	Tpeak hrs	R.V. mm	R.C.	Qbase cms
-------------	--------	-----------	------------	--------------	--------------	------------	------	--------------

START @ 0.00 hrs

CHIC STORM 10.0
[Ptot= 74.44 mm]

*
** CALIB NASHYD 0102 1 5.0 16.00 0.29 3.25 19.09 0.26 0.000
[CN=61.6]
[N = 3.0:Tp 1.02]

CHIC STORM 10.0
[Ptot= 74.44 mm]

*
** CALIB NASHYD 0101 1 5.0 6.20 0.26 2.50 24.76 0.33 0.000
[CN=67.6]
[N = 3.0:Tp 0.48]

=====
=====

```

V  V  I  SSSSS  U  U  A  L          (v 6.2.2015)
V  V  I  SS    U  U  A  A  L
V  V  I  SS    U  U  AAAAA  L
V  V  I  SS    U  U  A  A  L
  VV  I  SSSSS  UUUUU  A  A  LLLLL

```

```

000  TTTTT  TTTTT  H  H  Y  Y  M  M  000  TM
0  0  T  T  H  H  Y  Y  MM  MM  0  0
0  0  T  T  H  H  Y  M  M  0  0
000  T  T  H  H  Y  M  M  000

```

Developed and Distributed by Smart City Water Inc
Copyright 2007 - 2022 Smart City Water Inc
All rights reserved.

***** S U M M A R Y O U T P U T *****

Input filename: C:\Program Files (x86)\Visual OTTHYMO 6.2\VO2\voin.dat

Output filename:

C:\Users\hyu\AppData\Local\Civica\H5\2c2d2be-418b-4c4d-a4c4-d228733f752c\8aa7217f-88ec-464b-8b0c-798d9f9dd927\scenario

Summary filename:

C:\Users\hyu\AppData\Local\Civica\H5\2c2d2be-418b-4c4d-a4c4-d228733f752c\8aa7217f-

88ec-464b-8b0c-798d9f9dd927\scenario

DATE: 01/21/2025

TIME: 03:17:44

USER:

COMMENTS: _____

** SIMULATION : 6 **

W/E COMMAND	HYD ID	DT min	AREA ha	Qpeak cms	Tpeak hrs	R.V. mm	R.C.	Qbase cms
-------------	--------	-----------	------------	--------------	--------------	------------	------	--------------

START @ 0.00 hrs

CHIC STORM 10.0
[Ptot= 82.32 mm]

*

** CALIB NASHYD	0102	1	5.0	16.00	0.36	3.25	23.16	0.28	0.000
[CN=61.6									
[N = 3.0:Tp 1.02]									

*

CHIC STORM 10.0
[Ptot= 82.32 mm]

*

** CALIB NASHYD	0101	1	5.0	6.20	0.31	2.50	29.55	0.36	0.000
[CN=67.6									
[N = 3.0:Tp 0.48]									

*

POST SCS

=====

```

V   V   I   SSSSS  U   U   A   L           (v 6.2.2015)
V   V   I   SS     U   U   A A  L
V   V   I   SS     U   U   AAAAA L
V   V   I   SS     U   U   A   A  L
  VV    I   SSSSS  UUUUU  A   A  LLLLL

```

```

000  TTTTT  TTTTT  H   H  Y   Y  M   M  000  TM
0   0   T    T    H   H  Y Y  MM MM  0   0
0   0   T    T    H   H  Y   M   M  0   0
000   T    T    H   H  Y   M   M  000

```

Developed and Distributed by Smart City Water Inc
 Copyright 2007 - 2022 Smart City Water Inc
 All rights reserved.

***** S U M M A R Y O U T P U T *****

Input filename: C:\Program Files (x86)\Visual OTTHYMO 6.2\V02\voin.dat

Output filename:

C:\Users\hyu\AppData\Local\Civica\XH5\e2c2d2be-418b-4c4d-a4c4-d228733f752c\dead66f3-c7bd-44fa-ab3e-b90bcaf4653d\scenario

Summary filename:

C:\Users\hyu\AppData\Local\Civica\XH5\e2c2d2be-418b-4c4d-a4c4-d228733f752c\dead66f3-c7bd-44fa-ab3e-b90bcaf4653d\scenario

DATE: 01/21/2025

TIME: 03:18:10

USER:

COMMENTS: _____

```

*****
** SIMULATION : Run 01           **
*****

```

W/E COMMAND	HYD ID	DT min	AREA ha	' Qpeak ' cms	Tpeak hrs	R.V. mm	R.C.	Qbase cms
-------------	--------	-----------	------------	------------------	--------------	------------	------	--------------

START @ 0.00 hrs

READ STORM 5.0

[Ptot= 49.09 mm]

fname :

C:\Users\hyu\AppData\Local\Temp\d7b8d37f-9d76-45bc-8aa2-d43d16f576a6\a83aa445-7986-4108-a295-abaadc5

remark: Ottawa Macdonald Cartier SCS 24 2yr

*

** CALIB NASHYD 0201 1 5.0 2.70 0.05 12.25 12.34 0.25 0.000

[CN=69.6]

[N = 3.0:Tp 0.40]

*

READ STORM 5.0

[Ptot= 49.09 mm]

fname :

C:\Users\hyu\AppData\Local\Temp\d7b8d37f-9d76-45bc-8aa2-d43d16f576a6\a83aa445-7986-4108-a295-abaadc5

remark: Ottawa Macdonald Cartier SCS 24 2yr

*

** CALIB NASHYD 0202 1 5.0 4.60 0.07 12.58 14.10 0.29 0.000

[CN=73.0]

[N = 3.0:Tp 0.63]

*

** Reservoir

OUTFLOW: 0096 1 5.0 4.60 0.00 25.17 8.48 n/a 0.000

*

READ STORM 5.0

[Ptot= 49.09 mm]

fname :

C:\Users\hyu\AppData\Local\Temp\d7b8d37f-9d76-45bc-8aa2-d43d16f576a6\a83aa445-7986-4108-a295-abaadc5

remark: Ottawa Macdonald Cartier SCS 24 2yr

*

* CALIB NASHYD 0203 1 5.0 11.00 0.09 12.75 9.04 0.18 0.000

[CN=64.0]

[N = 3.0:Tp 0.77]

*

READ STORM 5.0

[Ptot= 49.09 mm]

fname :

C:\Users\hyu\AppData\Local\Temp\d7b8d37f-9d76-45bc-8aa2-d43d16f576a6\a83aa445-7986-4108-a295-abaadc5

remark: Ottawa Macdonald Cartier SCS 24 2yr

*

* CALIB NASHYD 0204 1 5.0 3.90 0.09 12.08 10.34 0.21 0.000

[CN=66.8]

[N = 3.0:Tp 0.22]

```

*
** Reservoir
  OUTFLOW:          0099  1  5.0    3.90    0.00 24.17    9.14 n/a    0.000
*
  ADD [ 0203+ 0096] 0100  3  5.0    15.60    0.09 12.75    8.87 n/a    0.000
*
  ADD [ 0100+ 0099] 0100  1  5.0    19.50    0.09 12.75    8.93 n/a    0.000
*

```

```

=====
=====

```

```

  V  V  I  SSSSS  U  U  A  L                (v 6.2.2015)
  V  V  I  SS    U  U  A  A  L
  V  V  I  SS    U  U  AAAAA  L
  V  V  I  SS    U  U  A  A  L
  VV   I  SSSSS  UUUUU  A  A  LLLLL

```

```

  000  TTTT  TTTT  H  H  Y  Y  M  M  000  TM
  0  0  T    T  H  H  Y  Y  MM MM  0  0
  0  0  T    T  H  H  Y    M  M  0  0
  000  T    T  H  H  Y    M  M  000

```

Developed and Distributed by Smart City Water Inc
 Copyright 2007 - 2022 Smart City Water Inc
 All rights reserved.

***** S U M M A R Y O U T P U T *****

Input filename: C:\Program Files (x86)\Visual OTTHYM0 6.2\V02\voin.dat

Output filename:

C:\Users\hyu\AppData\Local\Civica\H5\e2c2d2be-418b-4c4d-a4c4-d228733f752c\6089f5e4-102e-4a5b-a814-c8492e2c4615\scenario

Summary filename:

C:\Users\hyu\AppData\Local\Civica\H5\e2c2d2be-418b-4c4d-a4c4-d228733f752c\6089f5e4-102e-4a5b-a814-c8492e2c4615\scenario

DATE: 01/21/2025

TIME: 03:18:10

USER:

COMMENTS: _____

```

*****
** SIMULATION : Run 02                **

```

W/E COMMAND	HYD ID	DT	AREA	Qpeak	Tpeak	R.V.	R.C.	Qbase
		min	ha	' cms	hrs	mm		cms

START @ 0.00 hrs

READ STORM 5.0

[Ptot= 65.91 mm]

fname :

C:\Users\hyu\AppData\Local\Temp\d7b8d37f-9d76-45bc-8aa2-d43d16f576a6\5aca6ac2-ef25-4c6b-b023-6eea581

remark: Ottawa Macdonald Cartier SCS 24 5yr

*

** CALIB NASHYD 0201 1 5.0 2.70 0.09 12.25 21.35 0.32 0.000

[CN=69.6]

[N = 3.0:Tp 0.40]

*

READ STORM 5.0

[Ptot= 65.91 mm]

fname :

C:\Users\hyu\AppData\Local\Temp\d7b8d37f-9d76-45bc-8aa2-d43d16f576a6\5aca6ac2-ef25-4c6b-b023-6eea581

remark: Ottawa Macdonald Cartier SCS 24 5yr

*

** CALIB NASHYD 0202 1 5.0 4.60 0.12 12.58 23.98 0.36 0.000

[CN=73.0]

[N = 3.0:Tp 0.63]

*

** Reservoir

OUTFLOW: 0096 1 5.0 4.60 0.00 24.67 16.70 n/a 0.000

*

READ STORM 5.0

[Ptot= 65.91 mm]

fname :

C:\Users\hyu\AppData\Local\Temp\d7b8d37f-9d76-45bc-8aa2-d43d16f576a6\5aca6ac2-ef25-4c6b-b023-6eea581

remark: Ottawa Macdonald Cartier SCS 24 5yr

*

* CALIB NASHYD 0203 1 5.0 11.00 0.17 12.75 16.53 0.25 0.000

[CN=64.0]

[N = 3.0:Tp 0.77]

*

READ STORM 5.0

[Ptot= 65.91 mm]

fname :

C:\Users\hyu\AppData\Local\Temp\d7b8d37f-9d76-45bc-8aa2-d43d16f576a6\5aca6ac2-ef25-4

c6b-b023-6eea581

remark: Ottawa Macdonald Cartier SCS 24 5yr

```

*
* CALIB NASHYD          0204  1  5.0   3.90   0.16 12.08  18.51 0.28   0.000
  [CN=66.8              ]
  [ N = 3.0:Tp 0.22]
*
** Reservoir
  OUTFLOW:              0099  1  5.0   3.90   0.01 20.25  17.31 n/a   0.000
*
  ADD [ 0203+ 0096] 0100  3  5.0  15.60   0.17 12.75  16.58 n/a   0.000
*
  ADD [ 0100+ 0099] 0100  1  5.0  19.50   0.17 12.75  16.73 n/a   0.000
*

```

```

=====
=====

```

```

V  V  I  SSSSS  U  U  A  L          (v 6.2.2015)
V  V  I  SS    U  U  A  A  L
V  V  I  SS    U  U  AAAAA L
V  V  I  SS    U  U  A  A  L
  VV   I  SSSSS  UUUUU  A  A  LLLLL

```

```

  000  TTTTT  TTTTT  H  H  Y  Y  M  M  000  TM
  0  0  T    T  H  H  Y  Y  MM MM  0  0
  0  0  T    T  H  H  Y    M  M  0  0
  000  T    T  H  H  Y    M  M  000

```

Developed and Distributed by Smart City Water Inc
 Copyright 2007 - 2022 Smart City Water Inc
 All rights reserved.

***** S U M M A R Y O U T P U T *****

Input filename: C:\Program Files (x86)\Visual OTTHYMO 6.2\V02\voin.dat

Output filename:

C:\Users\hyu\AppData\Local\Civica\XH5\e2c2d2be-418b-4c4d-a4c4-d228733f752c\99923c1e-310c-4a69-bb01-2f62b271433e\scenario

Summary filename:

C:\Users\hyu\AppData\Local\Civica\XH5\e2c2d2be-418b-4c4d-a4c4-d228733f752c\99923c1e-310c-4a69-bb01-2f62b271433e\scenario

DATE: 01/21/2025

TIME: 03:18:11

USER:

COMMENTS: _____

** SIMULATION : Run 03 **

W/E COMMAND	HYD ID	DT	AREA	Qpeak	Tpeak	R.V.	R.C.	Qbase
		min	ha	' cms	hrs	mm		cms

START @ 0.00 hrs

READ STORM 5.0

[Ptot= 77.00 mm]

fname :

C:\Users\hyu\AppData\Local\Temp\d7b8d37f-9d76-45bc-8aa2-d43d16f576a6\937e7433-4342-40da-96a5-67c3cdf

remark: Ottawa Macdonald Cartier SCS 24 10yr

*

** CALIB NASHYD 0201 1 5.0 2.70 0.12 12.25 28.08 0.36 0.000

[CN=69.6]

[N = 3.0:Tp 0.40]

*

READ STORM 5.0

[Ptot= 77.00 mm]

fname :

C:\Users\hyu\AppData\Local\Temp\d7b8d37f-9d76-45bc-8aa2-d43d16f576a6\937e7433-4342-40da-96a5-67c3cdf

remark: Ottawa Macdonald Cartier SCS 24 10yr

*

** CALIB NASHYD 0202 1 5.0 4.60 0.16 12.50 31.26 0.41 0.000

[CN=73.0]

[N = 3.0:Tp 0.63]

*

** Reservoir

OUTFLOW: 0096 1 5.0 4.60 0.01 24.50 23.34 n/a 0.000

*

READ STORM 5.0

[Ptot= 77.00 mm]

fname :

C:\Users\hyu\AppData\Local\Temp\d7b8d37f-9d76-45bc-8aa2-d43d16f576a6\937e7433-4342-40da-96a5-67c3cdf

remark: Ottawa Macdonald Cartier SCS 24 10yr

*

* CALIB NASHYD 0203 1 5.0 11.00 0.23 12.75 22.28 0.29 0.000

[CN=64.0]
[N = 3.0:Tp 0.77]

*

READ STORM 5.0
[Ptot= 77.00 mm]
fname :

C:\Users\hyu\AppData\Local\Temp\d7b8d37f-9d76-45bc-8aa2-d43d16f576a6\937e7433-4342-40da-96a5-67c3cdf

remark: Ottawa Macdonald Cartier SCS 24 10yr

*

* CALIB NASHYD 0204 1 5.0 3.90 0.22 12.08 24.70 0.32 0.000
[CN=66.8]
[N = 3.0:Tp 0.22]

*

** Reservoir
OUTFLOW: 0099 1 5.0 3.90 0.01 16.58 23.51 n/a 0.000

*

ADD [0203+ 0096] 0100 3 5.0 15.60 0.23 12.75 22.59 n/a 0.000

*

ADD [0100+ 0099] 0100 1 5.0 19.50 0.24 12.75 22.77 n/a 0.000

*

=====
=====

V V I SSSSS U U A L (v 6.2.2015)
V V I SS U U A A L
V V I SS U U AAAAA L
V V I SS U U A A L
VV I SSSSS UUUUU A A LLLLL

000 TTTTT TTTTT H H Y Y M M 000 TM
O O T T H H Y Y MM MM O O
O O T T H H Y M M O O
000 T T H H Y M M 000

Developed and Distributed by Smart City Water Inc
Copyright 2007 - 2022 Smart City Water Inc
All rights reserved.

***** S U M M A R Y O U T P U T *****

Input filename: C:\Program Files (x86)\Visual OTTHYMO 6.2\V02\voin.dat

Output filename:

C:\Users\hyu\AppData\Local\Civica\H5\2c2d2be-418b-4c4d-a4c4-d228733f752c\1139a1e8-57bf-4c01-b053-e8c6c76a8815\scenario

Summary filename:

C:\Users\hyu\AppData\Local\Civica\XH5\e2c2d2be-418b-4c4d-a4c4-d228733f752c\1139a1e8-57bf-4c01-b053-e8c6c76a8815\scenario

DATE: 01/21/2025

TIME: 03:18:10

USER:

COMMENTS: _____

** SIMULATION : Run 04 **

W/E COMMAND	HYD ID	DT min	AREA ha	Qpeak cms	Tpeak hrs	R.V. mm	R.C.	Qbase cms
-------------	--------	-----------	------------	--------------	--------------	------------	------	--------------

START @ 0.00 hrs

READ STORM 5.0
[Ptot= 91.08 mm]
fname :

C:\Users\hyu\AppData\Local\Temp\d7b8d37f-9d76-45bc-8aa2-d43d16f576a6\8677e260-0877-4303-925b-23f8544

remark: Ottawa Macdonald Cartier SCS 24 25yr

*
** CALIB NASHYD 0201 1 5.0 2.70 0.16 12.25 37.33 0.41 0.000
[CN=69.6]
[N = 3.0:Tp 0.40]

*
READ STORM 5.0
[Ptot= 91.08 mm]
fname :

C:\Users\hyu\AppData\Local\Temp\d7b8d37f-9d76-45bc-8aa2-d43d16f576a6\8677e260-0877-4303-925b-23f8544

remark: Ottawa Macdonald Cartier SCS 24 25yr

*
** CALIB NASHYD 0202 1 5.0 4.60 0.21 12.50 41.18 0.45 0.000
[CN=73.0]
[N = 3.0:Tp 0.63]

*
** Reservoir
OUTFLOW: 0096 1 5.0 4.60 0.01 24.17 32.73 n/a 0.000

*
READ STORM 5.0
[Ptot= 91.08 mm]

fname :
 C:\Users\hyu\AppData\Local\Temp\d7b8d37f-9d76-45bc-8aa2-d43d16f576a6\8677e260-0877-4303-925b-23f8544
 remark: Ottawa Macdonald Cartier SCS 24 25yr

*
 * CALIB NASHYD 0203 1 5.0 11.00 0.32 12.75 30.34 0.33 0.000
 [CN=64.0]
 [N = 3.0:Tp 0.77]

*
 READ STORM 5.0
 [Ptot= 91.08 mm]
 fname :

C:\Users\hyu\AppData\Local\Temp\d7b8d37f-9d76-45bc-8aa2-d43d16f576a6\8677e260-0877-4303-925b-23f8544
 remark: Ottawa Macdonald Cartier SCS 24 25yr

*
 * CALIB NASHYD 0204 1 5.0 3.90 0.30 12.08 33.31 0.37 0.000
 [CN=66.8]
 [N = 3.0:Tp 0.22]

*
 ** Reservoir
 OUTFLOW: 0099 1 5.0 3.90 0.01 16.25 32.12 n/a 0.000
 *
 ADD [0203+ 0096] 0100 3 5.0 15.60 0.32 12.75 31.04 n/a 0.000
 *
 ADD [0100+ 0099] 0100 1 5.0 19.50 0.33 12.75 31.26 n/a 0.000
 *

=====
 =====

```

V  V  I  SSSSS  U  U  A  L                (v 6.2.2015)
V  V  I  SS    U  U  A  A  L
V  V  I  SS    U  U  AAAAA  L
V  V  I  SS    U  U  A  A  L
  VV   I  SSSSS  UUUUU  A  A  LLLLL

```

```

000  TTTT  TTTT  H  H  Y  Y  M  M  000  TM
0  0  T    T  H  H  Y  Y  MM MM 0  0
0  0  T    T  H  H  Y  M  M  0  0
000  T    T  H  H  Y  M  M  000

```

Developed and Distributed by Smart City Water Inc
 Copyright 2007 - 2022 Smart City Water Inc
 All rights reserved.

***** SUMMARY OUTPUT *****

Input filename: C:\Program Files (x86)\Visual OTTHYMO 6.2\V02\voin.dat

Output filename:

C:\Users\hyu\AppData\Local\Civica\XH5\e2c2d2be-418b-4c4d-a4c4-d228733f752c\1d426451-2729-4b7f-923c-c04ace03d415\scenario

Summary filename:

C:\Users\hyu\AppData\Local\Civica\XH5\e2c2d2be-418b-4c4d-a4c4-d228733f752c\1d426451-2729-4b7f-923c-c04ace03d415\scenario

DATE: 01/21/2025

TIME: 03:18:10

USER:

COMMENTS: _____

** SIMULATION : Run 05 **

W/E COMMAND	HYD ID	DT min	AREA ha	Qpeak cms	Tpeak hrs	R.V. mm	R.C.	Qbase cms
-------------	--------	-----------	------------	--------------	--------------	------------	------	--------------

START @ 0.00 hrs

READ STORM 5.0
[Ptot=101.52 mm]
fname :

C:\Users\hyu\AppData\Local\Temp\d7b8d37f-9d76-45bc-8aa2-d43d16f576a6\55c88cf1-c07d-4de2-b4c7-fa9ea96

remark: Ottawa Macdonald Cartier SCS 24 50yr

*
** CALIB NASHYD 0201 1 5.0 2.70 0.19 12.25 44.61 0.44 0.000
[CN=69.6]
[N = 3.0:Tp 0.40]

*
READ STORM 5.0
[Ptot=101.52 mm]
fname :

C:\Users\hyu\AppData\Local\Temp\d7b8d37f-9d76-45bc-8aa2-d43d16f576a6\55c88cf1-c07d-4de2-b4c7-fa9ea96

remark: Ottawa Macdonald Cartier SCS 24 50yr

*
** CALIB NASHYD 0202 1 5.0 4.60 0.25 12.50 48.93 0.48 0.000
[CN=73.0]

[N = 3.0:Tp 0.63]

*

** Reservoir

OUTFLOW: 0096 1 5.0 4.60 0.01 21.08 40.21 n/a 0.000

*

READ STORM 5.0

[Ptot=101.52 mm]

fname :

C:\Users\hyu\AppData\Local\Temp\d7b8d37f-9d76-45bc-8aa2-d43d16f576a6\55c88cf1-c07d-4de2-b4c7-fa9ea96

remark: Ottawa Macdonald Cartier SCS 24 50yr

*

* CALIB NASHYD 0203 1 5.0 11.00 0.39 12.67 36.77 0.36 0.000

[CN=64.0]

[N = 3.0:Tp 0.77]

*

READ STORM 5.0

[Ptot=101.52 mm]

fname :

C:\Users\hyu\AppData\Local\Temp\d7b8d37f-9d76-45bc-8aa2-d43d16f576a6\55c88cf1-c07d-4de2-b4c7-fa9ea96

remark: Ottawa Macdonald Cartier SCS 24 50yr

*

* CALIB NASHYD 0204 1 5.0 3.90 0.36 12.08 40.14 0.40 0.000

[CN=66.8]

[N = 3.0:Tp 0.22]

*

** Reservoir

OUTFLOW: 0099 1 5.0 3.90 0.02 16.17 38.95 n/a 0.000

*

ADD [0203+ 0096] 0100 3 5.0 15.60 0.39 12.75 37.79 n/a 0.000

*

ADD [0100+ 0099] 0100 1 5.0 19.50 0.40 12.75 38.02 n/a 0.000

*

=====
=====

V V I SSSSS U U A L (v 6.2.2015)
V V I SS U U A A L
V V I SS U U AAAAA L
V V I SS U U A A L
VV I SSSSS UUUUU A A LLLLL

000 TTTTT TTTTT H H Y Y M M 000 TM
0 0 T T H H Y Y MM MM 0 0
0 0 T T H H Y M M 0 0
000 T T H H Y M M 000

Developed and Distributed by Smart City Water Inc
Copyright 2007 - 2022 Smart City Water Inc
All rights reserved.

***** S U M M A R Y O U T P U T *****

Input filename: C:\Program Files (x86)\Visual OTTHYMO 6.2\V02\voin.dat

Output filename:

C:\Users\hyu\AppData\Local\Civica\XH5\e2c2d2be-418b-4c4d-a4c4-d228733f752c\9bc938db-a743-44b2-9526-962bdda77969\scenario

Summary filename:

C:\Users\hyu\AppData\Local\Civica\XH5\e2c2d2be-418b-4c4d-a4c4-d228733f752c\9bc938db-a743-44b2-9526-962bdda77969\scenario

DATE: 01/21/2025

TIME: 03:18:11

USER:

COMMENTS: _____

** SIMULATION : Run 06 **

W/E COMMAND	HYD ID	DT min	AREA ha	Qpeak cms	Tpeak hrs	R.V. mm	R.C.	Qbase cms
-------------	--------	-----------	------------	--------------	--------------	------------	------	--------------

START @ 0.00 hrs

READ STORM 5.0
[Ptot=111.87 mm]
fname :

C:\Users\hyu\AppData\Local\Temp\d7b8d37f-9d76-45bc-8aa2-d43d16f576a6\e20e7578-d439-4ffb-8edc-8fe2588

remark: Ottawa Macdonald Cartier SCS 24 100yr

*
** CALIB NASHYD 0201 1 5.0 2.70 0.22 12.25 52.14 0.47 0.000

[CN=69.6]
[N = 3.0:Tp 0.40]

*
READ STORM 5.0

[Ptot=111.87 mm]
fname :

C:\Users\hyu\AppData\Local\Temp\d7b8d37f-9d76-45bc-8aa2-d43d16f576a6\20e7578-d439-4ffb-8edc-8fe2588

remark: Ottawa Macdonald Cartier SCS 24 100yr

```

*
** CALIB NASHYD      0202  1  5.0   4.60   0.30 12.50  56.90 0.51   0.000
   [CN=73.0          ]
   [ N = 3.0:Tp 0.63]

```

```

*
** Reservoir
   OUTFLOW:          0096  1  5.0   4.60   0.02 20.75  47.96 n/a   0.000

```

```

*
   READ STORM              5.0
   [ Ptot=111.87 mm ]
   fname :

```

C:\Users\hyu\AppData\Local\Temp\d7b8d37f-9d76-45bc-8aa2-d43d16f576a6\20e7578-d439-4ffb-8edc-8fe2588

remark: Ottawa Macdonald Cartier SCS 24 100yr

```

*
* CALIB NASHYD      0203  1  5.0  11.00   0.46 12.67  43.49 0.39   0.000
   [CN=64.0          ]
   [ N = 3.0:Tp 0.77]

```

```

*
   READ STORM              5.0
   [ Ptot=111.87 mm ]
   fname :

```

C:\Users\hyu\AppData\Local\Temp\d7b8d37f-9d76-45bc-8aa2-d43d16f576a6\20e7578-d439-4ffb-8edc-8fe2588

remark: Ottawa Macdonald Cartier SCS 24 100yr

```

*
* CALIB NASHYD      0204  1  5.0   3.90   0.43 12.08  47.25 0.42   0.000
   [CN=66.8          ]
   [ N = 3.0:Tp 0.22]

```

```

*
** Reservoir
   OUTFLOW:          0099  1  5.0   3.90   0.02 16.00  46.05 n/a   0.000

```

```

*
   ADD [ 0203+ 0096] 0100  3  5.0  15.60   0.46 12.75  44.81 n/a   0.000

```

```

*
   ADD [ 0100+ 0099] 0100  1  5.0  19.50   0.48 12.75  45.06 n/a   0.000

```

```

*
FINISH

```

```

=====
=====

```

POST 3HR CHI

=====

```

V   V   I   SSSSS  U   U   A   L           (v 6.2.2015)
V   V   I   SS     U   U   A A  L
V   V   I   SS     U   U   AAAAA L
V   V   I   SS     U   U   A   A  L
  VV    I   SSSSS  UUUUU  A   A  LLLLL

```

```

  000  TTTTT  TTTTT  H   H  Y   Y  M   M   000  TM
  0   0   T    T    H   H   Y Y  MM MM  0   0
  0   0   T    T    H   H   Y   M   M  0   0
  000   T    T    H   H   Y   M   M  000

```

Developed and Distributed by Smart City Water Inc
 Copyright 2007 - 2022 Smart City Water Inc
 All rights reserved.

***** S U M M A R Y O U T P U T *****

Input filename: C:\Program Files (x86)\Visual OTTHYMO 6.2\V02\voin.dat

Output filename:

C:\Users\hyu\AppData\Local\Civica\XH5\e2c2d2be-418b-4c4d-a4c4-d228733f752c\9a85cccc-56c5-4bc5-8e11-df7c3305041a\scenario

Summary filename:

C:\Users\hyu\AppData\Local\Civica\XH5\e2c2d2be-418b-4c4d-a4c4-d228733f752c\9a85cccc-56c5-4bc5-8e11-df7c3305041a\scenario

DATE: 01/21/2025

TIME: 03:19:40

USER:

COMMENTS: _____

```

*****
** SIMULATION : 1 **
*****

```

W/E COMMAND	HYD ID	DT min	AREA ha	' Qpeak ' cms	Tpeak hrs	R.V. mm	R.C.	Qbase cms
-------------	--------	-----------	------------	------------------	--------------	------------	------	--------------

START @ 0.00 hrs

READ STORM 10.0

[Ptot= 25.00 mm]

fname :

C:\Users\hyu\AppData\Local\Temp\3f1c6071-4e2b-42da-b27e-30dbf8356f0c\ed1aeef3-57d0-4944-a888-6b10dc9

remark: 25MM4HR

*

** CALIB NASHYD 0202 1 5.0 4.60 0.02 2.17 3.52 0.14 0.000

[CN=73.0]

[N = 3.0:Tp 0.63]

*

** Reservoir

OUTFLOW: 0096 1 5.0 4.60 0.00 6.00 0.22 n/a 0.000

*

READ STORM 10.0

[Ptot= 25.00 mm]

fname :

C:\Users\hyu\AppData\Local\Temp\3f1c6071-4e2b-42da-b27e-30dbf8356f0c\ed1aeef3-57d0-4944-a888-6b10dc9

remark: 25MM4HR

*

* CALIB NASHYD 0203 1 5.0 11.00 0.02 2.50 1.74 0.07 0.000

[CN=64.0]

[N = 3.0:Tp 0.77]

*

READ STORM 10.0

[Ptot= 25.00 mm]

fname :

C:\Users\hyu\AppData\Local\Temp\3f1c6071-4e2b-42da-b27e-30dbf8356f0c\ed1aeef3-57d0-4944-a888-6b10dc9

remark: 25MM4HR

*

* CALIB NASHYD 0204 1 5.0 3.90 0.02 1.67 2.15 0.09 0.000

[CN=66.8]

[N = 3.0:Tp 0.22]

*

** Reservoir

OUTFLOW: 0099 1 5.0 3.90 0.00 4.50 0.96 n/a 0.000

*

ADD [0203+ 0096] 0100 3 5.0 15.60 0.02 2.50 1.29 n/a 0.000

*

ADD [0100+ 0099] 0100 1 5.0 19.50 0.02 2.50 1.22 n/a 0.000

*

READ STORM 10.0

[Ptot= 25.00 mm]

fname :

C:\Users\hyu\AppData\Local\Temp\3f1c6071-4e2b-42da-b27e-30dbf8356f0c\ed1aeef3-57d0-4

944-a888-6b10dc9
remark: 25MM4HR

*
* CALIB NASHYD 0075 1 5.0 2.70 0.01 1.83 2.94 0.12 0.000
[CN=69.6]
[N = 3.0:Tp 0.40]
*

=====
=====

V V I SSSSS U U A L (v 6.2.2015)
V V I SS U U A A L
V V I SS U U AAAAA L
V V I SS U U A A L
VV I SSSSS UUUUU A A LLLLL

000 TTTT TTTT H H Y Y M M 000 TM
0 0 T T H H Y Y MM MM 0 0
0 0 T T H H Y M M 0 0
000 T T H H Y M M 000

Developed and Distributed by Smart City Water Inc
Copyright 2007 - 2022 Smart City Water Inc
All rights reserved.

***** S U M M A R Y O U T P U T *****

Input filename: C:\Program Files (x86)\Visual OTTHYM0 6.2\V02\voin.dat

Output filename:
C:\Users\hyu\AppData\Local\Civica\H5\e2c2d2be-418b-4c4d-a4c4-d228733f752c\45d11468-a6c7-4db1-9d24-1b3172315f30\scenario

Summary filename:
C:\Users\hyu\AppData\Local\Civica\H5\e2c2d2be-418b-4c4d-a4c4-d228733f752c\45d11468-a6c7-4db1-9d24-1b3172315f30\scenario

DATE: 01/21/2025 TIME: 03:19:40

USER:

COMMENTS: _____

** SIMULATION : 2 **

W/E COMMAND	HYD ID	DT min	AREA ha	Qpeak cms	Tpeak hrs	R.V. mm	R.C.	Qbase cms
-------------	--------	--------	---------	-----------	-----------	---------	------	-----------

START @ 0.00 hrs

CHIC STORM 10.0
[Ptot= 31.86 mm]

*
** CALIB NASHYD 0202 1 5.0 4.60 0.04 1.83 5.98 0.19 0.000
[CN=73.0]
[N = 3.0:Tp 0.63]

*
** Reservoir
OUTFLOW: 0096 1 5.0 4.60 0.00 5.17 2.69 n/a 0.000

CHIC STORM 10.0
[Ptot= 31.86 mm]

*
* CALIB NASHYD 0203 1 5.0 11.00 0.05 2.08 3.32 0.10 0.000
[CN=64.0]
[N = 3.0:Tp 0.77]

CHIC STORM 10.0
[Ptot= 31.86 mm]

*
* CALIB NASHYD 0204 1 5.0 3.90 0.04 1.25 3.96 0.12 0.000
[CN=66.8]
[N = 3.0:Tp 0.22]

*
** Reservoir
OUTFLOW: 0099 1 5.0 3.90 0.00 3.50 2.77 n/a 0.000

*
ADD [0203+ 0096] 0100 3 5.0 15.60 0.05 2.08 3.14 n/a 0.000

*
ADD [0100+ 0099] 0100 1 5.0 19.50 0.05 2.08 3.06 n/a 0.000

CHIC STORM 10.0
[Ptot= 31.86 mm]

*
* CALIB NASHYD 0075 1 5.0 2.70 0.03 1.50 5.09 0.16 0.000
[CN=69.6]
[N = 3.0:Tp 0.40]

*

=====

```

*
** Reservoir
OUTFLOW:          0096  1  5.0   4.60   0.00  5.08   6.75  n/a   0.000
*
CHIC STORM
[ Ptot= 42.51 mm ]
*
* CALIB NASHYD    0203  1  5.0   11.00   0.10  2.08   6.59  0.16   0.000
  [CN=64.0        ]
  [ N = 3.0:Tp 0.77]
*
CHIC STORM
[ Ptot= 42.51 mm ]
*
* CALIB NASHYD    0204  1  5.0    3.90   0.09  1.25   7.63  0.18   0.000
  [CN=66.8        ]
  [ N = 3.0:Tp 0.22]
*
** Reservoir
OUTFLOW:          0099  1  5.0    3.90   0.00  3.50   6.44  n/a   0.000
*
ADD [ 0203+ 0096] 0100  3  5.0   15.60   0.10  2.08   6.64  n/a   0.000
*
ADD [ 0100+ 0099] 0100  1  5.0   19.50   0.10  2.08   6.60  n/a   0.000
*
CHIC STORM
[ Ptot= 42.51 mm ]
*
* CALIB NASHYD    0075  1  5.0    2.70   0.05  1.50   9.30  0.22   0.000
  [CN=69.6        ]
  [ N = 3.0:Tp 0.40]
*
FINISH

```

```

=====
=====
=====
=====
=====
=====

```

```

V   V   I   SSSSS  U   U   A   L           (v 6.2.2015)
V   V   I   SS    U   U   A A  L
V   V   I   SS    U   U   AAAAA L
V   V   I   SS    U   U   A   A  L
  VV    I   SSSSS  UUUUU  A   A  LLLLL
000   TTTTT  TTTTT  H   H   Y   Y   M   M   000   TM
0   0   T     T     H   H   Y   Y   MM  MM  0   0
0   0   T     T     H   H   Y   M   M   0   0

```

000 T T H H Y M M 000
 Developed and Distributed by Smart City Water Inc
 Copyright 2007 - 2022 Smart City Water Inc
 All rights reserved.

***** S U M M A R Y O U T P U T *****

Input filename: C:\Program Files (x86)\Visual OTTHYMO 6.2\V02\voin.dat

Output filename:

C:\Users\hyu\AppData\Local\Civica\XH5\e2c2d2be-418b-4c4d-a4c4-d228733f752c\5cb3000d-
 d539-4e83-9cad-93c580d190d7\scenario

Summary filename:

C:\Users\hyu\AppData\Local\Civica\XH5\e2c2d2be-418b-4c4d-a4c4-d228733f752c\5cb3000d-
 d539-4e83-9cad-93c580d190d7\scenario

DATE: 01/21/2025

TIME: 03:19:40

USER:

COMMENTS: _____

 ** SIMULATION : 4 **

W/E COMMAND	HYD ID	DT	AREA	Qpeak	Tpeak	R.V.	R.C.	Qbase
		min	ha	cms	hrs	mm		cms

START @ 0.00 hrs

 CHIC STORM 10.0
 [Ptot= 49.50 mm]

* ** CALIB NASHYD	0202	1	5.0	4.60	0.10	1.75	14.32	0.29	0.000
[CN=73.0]									
[N = 3.0:Tp 0.63]									

* ** Reservoir									
OUTFLOW:	0096	1	5.0	4.60	0.00	5.00	9.09	n/a	0.000

CHIC STORM 10.0
 [Ptot= 49.50 mm]

* ** CALIB NASHYD	0203	1	5.0	11.00	0.14	2.00	9.20	0.19	0.000
-------------------	------	---	-----	-------	------	------	------	------	-------

```

[CN=64.0      ]
[ N = 3.0:Tp 0.77]
*
CHIC STORM                10.0
[ Ptot= 49.50 mm ]
*
* CALIB NASHYD            0204 1 5.0   3.90   0.12  1.25  10.52 0.21  0.000
  [CN=66.8      ]
  [ N = 3.0:Tp 0.22]
*
** Reservoir
OUTFLOW:                  0099 1 5.0   3.90   0.00  3.50   9.32 n/a  0.000
*
ADD [ 0203+ 0096] 0100 3 5.0  15.60   0.14  2.00   9.17 n/a  0.000
*
ADD [ 0100+ 0099] 0100 1 5.0  19.50   0.14  2.00   9.20 n/a  0.000
*
CHIC STORM                10.0
[ Ptot= 49.50 mm ]
*
* CALIB NASHYD            0075 1 5.0   2.70   0.07  1.50  12.54 0.25  0.000
  [CN=69.6      ]
  [ N = 3.0:Tp 0.40]
*

```

```

=====
=====

```

```

V  V  I  SSSSS  U  U  A  L                (v 6.2.2015)
V  V  I  SS    U  U  A  A  L
V  V  I  SS    U  U  AAAAA  L
V  V  I  SS    U  U  A  A  L
VV   I  SSSSS  UUUUU  A  A  LLLLL

```

```

000  TTTT  TTTT  H  H  Y  Y  M  M  000  TM
0  0  T    T    H  H  Y  Y  MM MM  0  0
0  0  T    T    H  H  Y    M  M  0  0
000  T    T    H  H  Y    M  M  000

```

Developed and Distributed by Smart City Water Inc
 Copyright 2007 - 2022 Smart City Water Inc
 All rights reserved.

***** S U M M A R Y O U T P U T *****

Input filename: C:\Program Files (x86)\Visual OTTHYM0 6.2\V02\voin.dat

Output filename:
 C:\Users\hyu\AppData\Local\Civica\H5\e2c2d2be-418b-4c4d-a4c4-d228733f752c\2fc9bdf5-

9522-4938-9f9b-2a5d73bc5d51\scenario

Summary filename:

C:\Users\hyu\AppData\Local\Civica\XH5\2c2d2be-418b-4c4d-a4c4-d228733f752c\2fc9bdf5-9522-4938-9f9b-2a5d73bc5d51\scenario

DATE: 01/21/2025

TIME: 03:19:39

USER:

COMMENTS: _____

** SIMULATION : 5 **

W/E COMMAND	HYD ID	DT min	AREA ha	Qpeak cms	Tpeak hrs	R.V. mm	R.C.	Qbase cms
-------------	--------	-----------	------------	--------------	--------------	------------	------	--------------

START @ 0.00 hrs

CHIC STORM
[Ptot= 58.23 mm]

** CALIB NASHYD	0202	1 5.0	4.60	0.14	1.75	19.27	0.33	0.000
[CN=73.0]								
[N = 3.0:Tp 0.63]								

** Reservoir OUTFLOW:	0096	1 5.0	4.60	0.00	4.75	13.12	n/a	0.000
--------------------------	------	-------	------	------	------	-------	-----	-------

CHIC STORM
[Ptot= 58.23 mm]

* CALIB NASHYD	0203	1 5.0	11.00	0.19	2.00	12.91	0.22	0.000
[CN=64.0]								
[N = 3.0:Tp 0.77]								

CHIC STORM
[Ptot= 58.23 mm]

* CALIB NASHYD	0204	1 5.0	3.90	0.17	1.25	14.57	0.25	0.000
[CN=66.8]								
[N = 3.0:Tp 0.22]								

** Reservoir OUTFLOW:	0099	1 5.0	3.90	0.01	3.42	13.38	n/a	0.000
--------------------------	------	-------	------	------	------	-------	-----	-------

```

*   ADD [ 0203+ 0096] 0100 3 5.0 15.60 0.19 2.00 12.97 n/a 0.000
*   ADD [ 0100+ 0099] 0100 1 5.0 19.50 0.20 2.00 13.05 n/a 0.000
*   CHIC STORM
    [ Ptot= 58.23 mm ]
*   10.0
*   CALIB NASHYD      0075 1 5.0 2.70 0.10 1.42 17.04 0.29 0.000
    [CN=69.6          ]
    [ N = 3.0:Tp 0.40]
*

```

```

=====
=====

```

```

V   V   I   SSSSS U   U   A   L           (v 6.2.2015)
V   V   I   SS    U   U   A A  L
V   V   I   SS    U   U   AAAAA L
V   V   I   SS    U   U   A   A  L
  VV    I   SSSSS UUUUU A   A  LLLLL

```

```

000  TTTTT  TTTTT  H   H   Y   Y   M   M   000  TM
0 0  T    T    H   H   Y Y   MM MM 0 0
0 0  T    T    H   H   Y   M   M 0 0
000  T    T    H   H   Y   M   M 000

```

Developed and Distributed by Smart City Water Inc
 Copyright 2007 - 2022 Smart City Water Inc
 All rights reserved.

***** S U M M A R Y O U T P U T *****

Input filename: C:\Program Files (x86)\Visual OTTHYMO 6.2\V02\voin.dat

Output filename:

C:\Users\hyu\AppData\Local\Civica\XH5\e2c2d2be-418b-4c4d-a4c4-d228733f752c\8e3d322e-7d04-4792-bcbf-506800d889ba\scenario

Summary filename:

C:\Users\hyu\AppData\Local\Civica\XH5\e2c2d2be-418b-4c4d-a4c4-d228733f752c\8e3d322e-7d04-4792-bcbf-506800d889ba\scenario

DATE: 01/21/2025

TIME: 03:19:40

USER:

COMMENTS: _____

 ** SIMULATION : 6 **

W/E COMMAND	HYD ID	DT min	AREA ha	Qpeak cms	Tpeak hrs	R.V. mm	R.C.	Qbase cms
-------------	--------	--------	---------	-----------	-----------	---------	------	-----------

START @ 0.00 hrs

 CHIC STORM 10.0
 [Ptot= 64.81 mm]

*
 ** CALIB NASHYD 0202 1 5.0 4.60 0.17 1.75 23.28 0.36 0.000
 [CN=73.0]
 [N = 3.0:Tp 0.63]

*
 ** Reservoir
 OUTFLOW: 0096 1 5.0 4.60 0.00 4.67 16.66 n/a 0.000

CHIC STORM 10.0
 [Ptot= 64.81 mm]

*
 * CALIB NASHYD 0203 1 5.0 11.00 0.24 2.00 15.99 0.25 0.000
 [CN=64.0]
 [N = 3.0:Tp 0.77]

CHIC STORM 10.0
 [Ptot= 64.81 mm]

*
 * CALIB NASHYD 0204 1 5.0 3.90 0.22 1.25 17.92 0.28 0.000
 [CN=66.8]
 [N = 3.0:Tp 0.22]

*
 ** Reservoir
 OUTFLOW: 0099 1 5.0 3.90 0.01 3.33 16.73 n/a 0.000

*
 ADD [0203+ 0096] 0100 3 5.0 15.60 0.24 2.00 16.19 n/a 0.000

*
 ADD [0100+ 0099] 0100 1 5.0 19.50 0.25 2.00 16.30 n/a 0.000

CHIC STORM 10.0
 [Ptot= 64.81 mm]

*
 * CALIB NASHYD 0075 1 5.0 2.70 0.12 1.42 20.71 0.32 0.000
 [CN=69.6]
 [N = 3.0:Tp 0.40]

=====
 =====

```

V   V   I   SSSSS U   U   A   L           (v 6.2.2015)
V   V   I   SS    U   U   A A  L
V   V   I   SS    U   U   AAAAA L
V   V   I   SS    U   U   A   A  L
W   I   SSSSS UUUUU A   A  LLLLL

```

```

000  TTTTT  TTTTT  H   H  Y   Y  M   M  000  TM
0  0  T     T   H   H  Y Y  MM MM 0  0
0  0  T     T   H   H  Y   M   M  0  0
000  T     T   H   H  Y   M   M  000

```

Developed and Distributed by Smart City Water Inc
 Copyright 2007 - 2022 Smart City Water Inc
 All rights reserved.

***** S U M M A R Y O U T P U T *****

Input filename: C:\Program Files (x86)\Visual OTTHYMO 6.2\V02\voin.dat

Output filename:

C:\Users\hyu\AppData\Local\Civica\XH5\e2c2d2be-418b-4c4d-a4c4-d228733f752c\818e737e-2635-4433-be16-48bf9d3094dd\scenario

Summary filename:

C:\Users\hyu\AppData\Local\Civica\XH5\e2c2d2be-418b-4c4d-a4c4-d228733f752c\818e737e-2635-4433-be16-48bf9d3094dd\scenario

DATE: 01/21/2025

TIME: 03:19:40

USER:

COMMENTS: _____

```

*****
** SIMULATION : 7 **
*****

```

W/E COMMAND	HYD ID	DT min	AREA ha	Qpeak cms	Tpeak hrs	R.V. mm	R.C.	Qbase cms
-------------	--------	-----------	------------	--------------	--------------	------------	------	--------------

START @ 0.00 hrs

 CHIC STORM 10.0
 [Ptot= 71.66 mm]

*

POST 6HR CHI

=====

```

V   V   I   SSSSS  U   U   A   L           (v 6.2.2015)
V   V   I   SS     U   U   A A  L
V   V   I   SS     U   U   AAAAA L
V   V   I   SS     U   U   A   A  L
  VV    I   SSSSS  UUUUU  A   A  LLLLL

```

```

  000  TTTTT  TTTTT  H   H  Y   Y  M   M   000  TM
  0   0   T    T    H   H   Y Y  MM MM  0   0
  0   0   T    T    H   H   Y   M   M  0   0
  000   T    T    H   H   Y   M   M  000

```

Developed and Distributed by Smart City Water Inc
 Copyright 2007 - 2022 Smart City Water Inc
 All rights reserved.

***** S U M M A R Y O U T P U T *****

Input filename: C:\Program Files (x86)\Visual OTTHYMO 6.2\V02\voin.dat

Output filename:

C:\Users\hyu\AppData\Local\Civica\XH5\e2c2d2be-418b-4c4d-a4c4-d228733f752c\0b60fc45-aa96-4a31-809f-7bc8c5c4d132\scenario

Summary filename:

C:\Users\hyu\AppData\Local\Civica\XH5\e2c2d2be-418b-4c4d-a4c4-d228733f752c\0b60fc45-aa96-4a31-809f-7bc8c5c4d132\scenario

DATE: 01/21/2025

TIME: 03:19:59

USER:

COMMENTS: _____

```

*****
** SIMULATION : 1 **
*****

```

W/E COMMAND	HYD ID	DT min	AREA ha	' Qpeak ' cms	Tpeak hrs	R.V. mm	R.C.	Qbase cms
-------------	--------	-----------	------------	------------------	--------------	------------	------	--------------

START @ 0.00 hrs

```

CHIC STORM                10.0
[ Ptot= 36.86 mm ]
*
** CALIB NASHYD           0202  1  5.0   4.60   0.05  2.75   8.08  0.22   0.000
[CN=73.0                   ]
[ N = 3.0:Tp 0.63]
*
** Reservoir
OUTFLOW:                 0096  1  5.0   4.60   0.00  7.75   4.79  n/a   0.000
*
CHIC STORM                10.0
[ Ptot= 36.86 mm ]
*
* CALIB NASHYD           0203  1  5.0  11.00   0.05  3.08   4.74  0.13   0.000
[CN=64.0                   ]
[ N = 3.0:Tp 0.77]
*
CHIC STORM                10.0
[ Ptot= 36.86 mm ]
*
* CALIB NASHYD           0204  1  5.0   3.90   0.05  2.25   5.57  0.15   0.000
[CN=66.8                   ]
[ N = 3.0:Tp 0.22]
*
** Reservoir
OUTFLOW:                 0099  1  5.0   3.90   0.00  6.42   4.37  n/a   0.000
*
ADD [ 0203+ 0096]        0100  3  5.0  15.60   0.06  3.08   4.76  n/a   0.000
*
ADD [ 0100+ 0099]        0100  1  5.0  19.50   0.06  3.08   4.68  n/a   0.000
*
CHIC STORM                10.0
[ Ptot= 36.86 mm ]
*
* CALIB NASHYD           0075  1  5.0   2.70   0.03  2.50   6.95  0.19   0.000
[CN=69.6                   ]
[ N = 3.0:Tp 0.40]
*

```

```

=====
=====

```

```

V   V   I   SSSSS  U   U   A   L           (v 6.2.2015)
V   V   I   SS    U   U   A A  L
V   V   I   SS    U   U  AAAAA L
V   V   I   SS    U   U   A   A  L
  VV    I   SSSSS  UUUUU  A   A  LLLLL
      000  TTTTT  TTTTT  H   H   Y   Y   M   M   000  TM
      0   0   T     T     H   H   Y Y   MM MM  0   0

```

O O T T H H Y M M O O
000 T T H H Y M M 000

Developed and Distributed by Smart City Water Inc
Copyright 2007 - 2022 Smart City Water Inc
All rights reserved.

***** S U M M A R Y O U T P U T *****

Input filename: C:\Program Files (x86)\Visual OTTHYM0 6.2\V02\voin.dat

Output filename:

C:\Users\hyu\AppData\Local\Civica\XH5\e2c2d2be-418b-4c4d-a4c4-d228733f752c\66c558b2-cc29-445f-8d1f-125a69c97441\scenario

Summary filename:

C:\Users\hyu\AppData\Local\Civica\XH5\e2c2d2be-418b-4c4d-a4c4-d228733f752c\66c558b2-cc29-445f-8d1f-125a69c97441\scenario

DATE: 01/21/2025

TIME: 03:19:59

USER:

COMMENTS: _____

** SIMULATION : 2 **

W/E COMMAND	HYD ID	DT min	AREA ha	Qpeak cms	Tpeak hrs	R.V. mm	R.C.	Qbase cms
-------------	--------	-----------	------------	--------------	--------------	------------	------	--------------

START @ 0.00 hrs

CHIC STORM 10.0
[Ptot= 49.04 mm]

*
** CALIB NASHYD 0202 1 5.0 4.60 0.09 2.75 14.07 0.29 0.000
[CN=73.0]
[N = 3.0:Tp 0.63]

*
** Reservoir
OUTFLOW: 0096 1 5.0 4.60 0.00 7.58 8.86 n/a 0.000

*
CHIC STORM 10.0
[Ptot= 49.04 mm]
*

```

* CALIB NASHYD      0203  1  5.0  11.00   0.11  3.00   9.02  0.18   0.000
  [CN=64.0          ]
  [ N = 3.0:Tp 0.77]
*
  CHIC STORM                10.0
  [ Ptot= 49.04 mm ]
*
* CALIB NASHYD      0204  1  5.0   3.90   0.10  2.25  10.31  0.21   0.000
  [CN=66.8          ]
  [ N = 3.0:Tp 0.22]
*
** Reservoir
  OUTFLOW:                  0099  1  5.0   3.90   0.00  6.33   9.12  n/a   0.000
*
  ADD [ 0203+ 0096] 0100  3  5.0  15.60   0.11  3.00   8.97  n/a   0.000
*
  ADD [ 0100+ 0099] 0100  1  5.0  19.50   0.11  3.00   9.00  n/a   0.000
*
  CHIC STORM                10.0
  [ Ptot= 49.04 mm ]
*
* CALIB NASHYD      0075  1  5.0   2.70   0.06  2.42  12.32  0.25   0.000
  [CN=69.6          ]
  [ N = 3.0:Tp 0.40]
*

```

```

=====
=====

```

```

V  V  I  SSSSS  U  U  A  L          (v 6.2.2015)
V  V  I  SS    U  U  A  A  L
V  V  I  SS    U  U  AAAAA  L
V  V  I  SS    U  U  A  A  L
  VV  I  SSSSS  UUUUU  A  A  LLLLL

```

```

000  TTTTT  TTTTT  H  H  Y  Y  M  M  000  TM
0  0  T  T  H  H  Y  Y  MM  MM  0  0
0  0  T  T  H  H  Y  M  M  0  0
000  T  T  H  H  Y  M  M  000

```

Developed and Distributed by Smart City Water Inc
 Copyright 2007 - 2022 Smart City Water Inc
 All rights reserved.

***** S U M M A R Y O U T P U T *****

Input filename: C:\Program Files (x86)\Visual OTTHYMO 6.2\V02\voin.dat
 Output filename:

C:\Users\hyu\AppData\Local\Civica\XH5\e2c2d2be-418b-4c4d-a4c4-d228733f752c\5806f6da-ce18-44ea-a167-4b8dd8b43bf2\scenario

Summary filename:

C:\Users\hyu\AppData\Local\Civica\XH5\e2c2d2be-418b-4c4d-a4c4-d228733f752c\5806f6da-ce18-44ea-a167-4b8dd8b43bf2\scenario

DATE: 01/21/2025

TIME: 03:19:59

USER:

COMMENTS: _____

** SIMULATION : 3 **

W/E COMMAND	HYD ID	DT min	AREA ha	Qpeak cms	Tpeak hrs	R.V. mm	R.C.	Qbase cms
-------------	--------	-----------	------------	--------------	--------------	------------	------	--------------

START @ 0.00 hrs

CHIC STORM 10.0
[Ptot= 57.02 mm]

* ** CALIB NASHYD	0202	1	5.0	4.60	0.12	2.75	18.56	0.33	0.000
[CN=73.0]									
[N = 3.0:Tp 0.63]									

* ** Reservoir									
OUTFLOW:	0096	1	5.0	4.60	0.00	7.33	12.45	n/a	0.000

CHIC STORM 10.0
[Ptot= 57.02 mm]

* CALIB NASHYD	0203	1	5.0	11.00	0.15	3.00	12.37	0.22	0.000
[CN=64.0]									
[N = 3.0:Tp 0.77]									

CHIC STORM 10.0
[Ptot= 57.02 mm]

* CALIB NASHYD	0204	1	5.0	3.90	0.14	2.25	13.98	0.25	0.000
[CN=66.8]									
[N = 3.0:Tp 0.22]									

* ** Reservoir									
OUTFLOW:	0099	1	5.0	3.90	0.00	6.25	12.79	n/a	0.000

```

*
*   ADD [ 0203+ 0096] 0100 3 5.0 15.60 0.16 3.00 12.39 n/a 0.000
*
*   ADD [ 0100+ 0099] 0100 1 5.0 19.50 0.16 3.00 12.47 n/a 0.000
*
*   CHIC STORM
*   [ Ptot= 57.02 mm ]
*
*   CALIB NASHYD 0075 1 5.0 2.70 0.08 2.42 16.39 0.29 0.000
*   [CN=69.6 ]
*   [ N = 3.0:Tp 0.40]
*

```

```

=====
=====

```

```

V   V   I   SSSSS U   U   A   L           (v 6.2.2015)
V   V   I   SS    U   U   A A  L
V   V   I   SS    U   U   AAAAA L
V   V   I   SS    U   U   A   A  L
  W    I   SSSSS UUUUU A   A  LLLLL

```

```

000  TTTTT  TTTTT H   H   Y   Y   M   M   000  TM
0 0  T    T  H   H   Y Y  MM MM 0 0
0 0  T    T  H   H   Y   M   M 0 0
000  T    T  H   H   Y   M   M 000

```

Developed and Distributed by Smart City Water Inc
 Copyright 2007 - 2022 Smart City Water Inc
 All rights reserved.

***** S U M M A R Y O U T P U T *****

Input filename: C:\Program Files (x86)\Visual OTTHYMO 6.2\V02\voin.dat

Output filename:

C:\Users\hyu\AppData\Local\Civica\XH5\e2c2d2be-418b-4c4d-a4c4-d228733f752c\1d15f647-0a0c-4ade-bb41-4b414f8c6bd9\scenario

Summary filename:

C:\Users\hyu\AppData\Local\Civica\XH5\e2c2d2be-418b-4c4d-a4c4-d228733f752c\1d15f647-0a0c-4ade-bb41-4b414f8c6bd9\scenario

DATE: 01/21/2025

TIME: 03:19:59

USER:

COMMENTS: _____

 ** SIMULATION : 4 **

W/E COMMAND	HYD ID	DT min	AREA ha	Qpeak cms	Tpeak hrs	R.V. mm	R.C.	Qbase cms
-------------	--------	--------	---------	-----------	-----------	---------	------	-----------

START @ 0.00 hrs

CHIC STORM 10.0
 [Ptot= 66.93 mm]

*
 ** CALIB NASHYD 0202 1 5.0 4.60 0.16 2.75 24.62 0.37 0.000
 [CN=73.0]
 [N = 3.0:Tp 0.63]

*
 ** Reservoir
 OUTFLOW: 0096 1 5.0 4.60 0.00 7.17 17.80 n/a 0.000

CHIC STORM 10.0
 [Ptot= 66.93 mm]

*
 * CALIB NASHYD 0203 1 5.0 11.00 0.22 2.92 17.03 0.25 0.000
 [CN=64.0]
 [N = 3.0:Tp 0.77]

CHIC STORM 10.0
 [Ptot= 66.93 mm]

*
 * CALIB NASHYD 0204 1 5.0 3.90 0.20 2.17 19.05 0.28 0.000
 [CN=66.8]
 [N = 3.0:Tp 0.22]

*
 ** Reservoir
 OUTFLOW: 0099 1 5.0 3.90 0.01 6.17 17.86 n/a 0.000

*
 ADD [0203+ 0096] 0100 3 5.0 15.60 0.22 3.00 17.26 n/a 0.000

*
 ADD [0100+ 0099] 0100 1 5.0 19.50 0.22 3.00 17.38 n/a 0.000

CHIC STORM 10.0
 [Ptot= 66.93 mm]

*
 * CALIB NASHYD 0075 1 5.0 2.70 0.11 2.42 21.95 0.33 0.000
 [CN=69.6]
 [N = 3.0:Tp 0.40]

=====

=====

```

V   V   I   SSSSS U   U   A   L           (v 6.2.2015)
V   V   I   SS   U   U   A A   L
V   V   I   SS   U   U   AAAAA L
V   V   I   SS   U   U   A   A   L
  WV   I   SSSSS UUUUU A   A   LLLLL

```

```

  000  TTTTT  TTTTT  H   H  Y   Y  M   M  000  TM
0   0   T     T   H   H  Y Y  MM MM  0   0
0   0   T     T   H   H  Y   M   M  0   0
  000   T     T   H   H  Y   M   M  000

```

Developed and Distributed by Smart City Water Inc
 Copyright 2007 - 2022 Smart City Water Inc
 All rights reserved.

***** S U M M A R Y O U T P U T *****

Input filename: C:\Program Files (x86)\Visual OTTHYMO 6.2\V02\voin.dat

Output filename:

C:\Users\hyu\AppData\Local\Civica\XH5\e2c2d2be-418b-4c4d-a4c4-d228733f752c\50bf424e-0944-4ecf-bf13-9b661fd3383e\scenario

Summary filename:

C:\Users\hyu\AppData\Local\Civica\XH5\e2c2d2be-418b-4c4d-a4c4-d228733f752c\50bf424e-0944-4ecf-bf13-9b661fd3383e\scenario

DATE: 01/21/2025

TIME: 03:19:59

USER:

COMMENTS: _____

```

*****
** SIMULATION : 5 **
*****

```

W/E COMMAND	HYD ID	DT min	AREA ha	Qpeak ' cms	Tpeak hrs	R.V. mm	R.C.	Qbase cms
-------------	--------	-----------	------------	----------------	--------------	------------	------	--------------

START @ 0.00 hrs

CHIC STORM			10.0					
------------	--	--	------	--	--	--	--	--

[Ptot= 74.44 mm]

```

*
** CALIB NASHYD      0202  1  5.0   4.60   0.19  2.75  29.53  0.40   0.000
   [CN=73.0          ]
   [ N = 3.0:Tp 0.63]
*
** Reservoir
OUTFLOW:            0096  1  5.0   4.60   0.01  7.08  22.30  n/a   0.000
*
CHIC STORM
[ Ptot= 74.44 mm ]
*
* CALIB NASHYD      0203  1  5.0  11.00   0.27  2.92  20.90  0.28   0.000
   [CN=64.0          ]
   [ N = 3.0:Tp 0.77]
*
CHIC STORM
[ Ptot= 74.44 mm ]
*
* CALIB NASHYD      0204  1  5.0   3.90   0.25  2.17  23.22  0.31   0.000
   [CN=66.8          ]
   [ N = 3.0:Tp 0.22]
*
** Reservoir
OUTFLOW:            0099  1  5.0   3.90   0.01  6.17  22.03  n/a   0.000
*
ADD [ 0203+ 0096]  0100  3  5.0  15.60   0.27  2.92  21.31  n/a   0.000
*
ADD [ 0100+ 0099]  0100  1  5.0  19.50   0.28  2.92  21.46  n/a   0.000
*
CHIC STORM
[ Ptot= 74.44 mm ]
*
* CALIB NASHYD      0075  1  5.0   2.70   0.14  2.42  26.48  0.36   0.000
   [CN=69.6          ]
   [ N = 3.0:Tp 0.40]
*
=====
=====

```

```

V  V  I  SSSSS  U  U  A  L          (v 6.2.2015)
V  V  I  SS    U  U  A  A  L
V  V  I  SS    U  U  AAAAA  L
V  V  I  SS    U  U  A  A  L
  VV  I  SSSSS  UUUUU  A  A  LLLLL
000  TTTTT  TTTTT  H  H  Y  Y  M  M  000  TM
0  0  T  T  H  H  Y  Y  MM  MM  0  0
0  0  T  T  H  H  Y  M  M  0  0
000  T  T  H  H  Y  M  M  000

```



```

* [ N = 3.0:Tp 0.77]
*
* CHIC STORM 10.0
* [ Ptot= 82.32 mm ]
*
* * CALIB NASHYD 0204 1 5.0 3.90 0.30 2.17 27.87 0.34 0.000
* [CN=66.8 ]
* [ N = 3.0:Tp 0.22]
*
* ** Reservoir
* OUTFLOW: 0099 1 5.0 3.90 0.02 6.08 26.67 n/a 0.000
*
* ADD [ 0203+ 0096] 0100 3 5.0 15.60 0.33 2.92 25.86 n/a 0.000
*
* ADD [ 0100+ 0099] 0100 1 5.0 19.50 0.34 2.92 26.02 n/a 0.000
*
* CHIC STORM 10.0
* [ Ptot= 82.32 mm ]
*
* * CALIB NASHYD 0075 1 5.0 2.70 0.17 2.42 31.49 0.38 0.000
* [CN=69.6 ]
* [ N = 3.0:Tp 0.40]
*

```

FINISH

```

=====
=====

```

Environment and Climate Change Canada
 Environnement et Changement climatique Canada

Short Duration Rainfall Intensity-Duration-Frequency Data
 Données sur l'intensité, la durée et la fréquence des chutes
 de pluie de courte durée

Gumbel - Method of moments/Méthode des moments

2021/03/26

```

=====
OTTAWA MACDONALD-CARTIER INT'L A                ON        6106000
Latitude: 45 19'N   Longitude: 75 40'W   Elevation/Altitude: 114      m
Years/Années : 1967 - 2016           # Years/Années : 46
=====
    
```

Table 1 : Annual Maximum (mm)/Maximum annuel (mm)

Year Année	5 min	10 min	15 min	30 min	1 h	2 h	6 h	12 h	24 h
1967	13.2	15.2	15.7	16.5	24.6	35.3	43.4	45.7	55.6
1968	8.1	14.0	18.5	23.1	33.3	34.0	41.1	44.7	44.7
1969	7.6	13.2	19.8	26.4	32.5	32.5	46.7	47.2	50.3
1970	14.5	23.4	27.7	34.3	35.6	36.6	43.2	43.4	43.4
1971	15.7	16.0	16.5	18.8	33.3	35.1	36.8	37.3	37.3
1972	11.4	17.3	23.4	31.7	38.1	38.4	48.8	53.8	60.5
1973	7.4	11.9	15.7	20.6	30.2	34.5	43.4	43.7	45.2
1974	5.6	7.9	10.2	19.3	20.6	30.7	31.0	35.8	39.1
1975	10.4	18.3	22.9	26.2	34.8	36.8	37.8	39.9	41.4
1976	9.7	12.7	13.5	13.7	14.5	18.3	27.9	28.2	33.0
1977	9.1	14.7	15.5	19.0	21.8	30.5	39.1	39.6	39.6
1978	17.5	22.2	29.3	35.5	36.2	36.3	36.3	36.5	39.4
1979	13.2	25.5	32.1	41.4	43.9	44.0	44.0	62.3	63.0
1980	8.9	16.0	17.4	17.8	18.3	18.4	28.3	42.8	47.2
1981	7.9	14.4	19.4	27.5	35.3	63.7	108.9	111.3	115.9
1982	7.1	10.6	14.1	19.7	20.9	21.5	35.0	40.3	40.3
1983	5.1	7.3	9.1	9.9	12.0	19.6	32.6	38.2	56.7
1984	8.2	9.3	11.7	16.4	18.4	19.4	26.1	36.1	44.3
1985	5.4	9.6	11.2	15.9	19.0	34.5	39.6	39.6	39.6
1986	12.2	21.0	24.4	31.1	34.9	35.6	42.4	46.0	69.3
1987	8.8	13.2	15.5	21.4	21.8	41.4	42.3	58.4	59.0

1988	12.7	17.0	21.0	24.2	28.2	36.4	44.2	45.4	45.8
1989	6.7	10.4	15.4	19.2	23.7	25.9	34.5	36.3	40.6
1990	10.4	12.6	13.6	17.5	20.8	24.7	35.0	53.5	54.0
1991	4.1	5.8	6.8	8.6	15.0	19.8	24.6	30.4	41.2
1992	6.2	10.3	13.8	19.6	31.5	37.4	43.3	49.7	54.2
1993	6.4	8.8	11.9	12.8	13.2	13.2	22.3	43.0	55.5
1994	15.6	20.0	21.8	23.6	23.8	23.8	32.5	35.0	42.9
1995	6.2	8.5	11.1	11.9	17.1	26.5	54.3	76.2	83.4
1996	6.4	11.9	14.3	18.9	26.9	27.1	33.0	35.6	44.1
1997	5.8	6.9	7.8	11.7	13.5	15.4	26.6	34.9	40.4
1998	9.1	12.1	12.3	15.8	15.8	17.8	24.0	30.5	43.6
1999	8.9	12.9	16.3	17.7	17.7	20.4	39.4	39.7	39.8
2000	7.7	8.7	9.9	11.5	15.9	19.6	38.8	46.7	46.7
2002	8.7	14.6	20.7	33.6	45.4	54.4	57.0	57.0	59.5
2003	7.4	10.8	12.1	17.1	20.0	20.0	26.1	38.2	44.6
2004	8.0	13.0	18.3	25.6	31.9	50.4	98.9	125.7	136.6
2006	11.3	12.8	14.9	16.9	18.1	21.3	40.0	46.1	50.7
2007	8.2	12.8	13.6	21.3	23.2	23.2	44.4	67.8	67.8
2008	7.6	12.0	15.9	18.3	20.9	23.5	33.1	44.8	49.6
2009	9.5	14.7	17.0	21.5	36.0	47.0	47.0	62.8	66.9
2010	8.4	15.5	17.6	21.4	29.0	33.1	35.6	41.4	46.6
2013	9.4	16.2	20.1	21.3	25.1	41.3	42.7	42.7	44.1
2014	11.4	17.7	19.4	22.8	24.9	26.6	33.4	46.2	56.2
2015	6.2	9.2	12.1	12.7	15.3	18.8	26.1	36.9	41.2
2016	9.5	14.2	14.6	14.8	16.4	24.6	35.6	37.3	40.4

# Yrs. Années	46	46	46	46	46	46	46	46	46
Mean Moyenne	9.1	13.5	16.4	20.6	25.0	30.2	40.2	47.3	52.2
Std. Dev. Écart-type	3.0	4.4	5.4	7.1	8.6	10.9	15.9	18.3	19.0
Skew. Dissymétrie	0.92	0.68	0.83	0.88	0.50	0.86	2.94	2.86	2.92
Kurtosis	3.69	3.60	3.99	3.91	2.50	3.87	13.66	12.49	13.04

*-99.9 Indicates Missing Data/Données manquantes

Warning: annual maximum amount greater than 100-yr return period amount
 Avertissement : la quantité maximale annuelle excède la quantité
 pour une période de retour de 100 ans

Year/Année	Duration/Durée	Data/Données	100-yr/ans
1981	6 h	108.9	89.9
1981	12 h	111.3	104.6
1981	24 h	115.9	111.9
2004	6 h	98.9	89.9
2004	12 h	125.7	104.6
2004	24 h	136.6	111.9

Table 2a : Return Period Rainfall Amounts (mm)
 Quantité de pluie (mm) par période de retour

Duration/Durée	2	5	10	25	50	100	#Years
	yr/ans	yr/ans	yr/ans	yr/ans	yr/ans	yr/ans	Années
5 min	8.6	11.3	13.0	15.3	16.9	18.5	46
10 min	12.8	16.7	19.2	22.5	24.9	27.2	46
15 min	15.5	20.3	23.5	27.5	30.5	33.4	46
30 min	19.4	25.7	29.8	35.1	39.0	42.9	46
1 h	23.6	31.2	36.2	42.6	47.3	52.0	46
2 h	28.4	38.1	44.5	52.6	58.6	64.5	46
6 h	37.5	51.6	60.9	72.6	81.3	89.9	46
12 h	44.3	60.4	71.1	84.6	94.7	104.6	46
24 h	49.1	65.9	77.0	91.1	101.5	111.9	46

Table 2b :

Return Period Rainfall Rates (mm/h) - 95% Confidence limits
 Intensité de la pluie (mm/h) par période de retour - Limites de confiance de 95%

Duration/Durée	2	5	10	25	50	100	#Years
	yr/ans	yr/ans	yr/ans	yr/ans	yr/ans	yr/ans	Années
5 min	103.3	135.2	156.3	183.0	202.8	222.5	46
	+/- 9.6	+/- 16.1	+/- 21.8	+/- 29.4	+/- 35.1	+/- 40.9	46
10 min	77.0	100.1	115.5	134.8	149.2	163.5	46
	+/- 6.9	+/- 11.7	+/- 15.8	+/- 21.3	+/- 25.5	+/- 29.7	46
15 min	62.2	81.3	94.0	110.0	121.9	133.7	46
	+/- 5.7	+/- 9.7	+/- 13.1	+/- 17.6	+/- 21.1	+/- 24.6	46
30 min	38.8	51.4	59.7	70.2	78.0	85.7	46
	+/- 3.8	+/- 6.3	+/- 8.6	+/- 11.6	+/- 13.8	+/- 16.1	46
1 h	23.6	31.2	36.2	42.6	47.3	52.0	46
	+/- 2.3	+/- 3.8	+/- 5.2	+/- 7.0	+/- 8.4	+/- 9.8	46
2 h	14.2	19.0	22.2	26.3	29.3	32.3	46
	+/- 1.5	+/- 2.4	+/- 3.3	+/- 4.5	+/- 5.3	+/- 6.2	46
6 h	6.3	8.6	10.1	12.1	13.5	15.0	46
	+/- 0.7	+/- 1.2	+/- 1.6	+/- 2.2	+/- 2.6	+/- 3.0	46
12 h	3.7	5.0	5.9	7.1	7.9	8.7	46
	+/- 0.4	+/- 0.7	+/- 0.9	+/- 1.2	+/- 1.5	+/- 1.7	46
24 h	2.0	2.7	3.2	3.8	4.2	4.7	46
	+/- 0.2	+/- 0.4	+/- 0.5	+/- 0.6	+/- 0.8	+/- 0.9	46

Table 3 : Interpolation Equation / Équation d'interpolation: $R = A \cdot T^B$

R = Interpolated Rainfall rate (mm/h)/Intensité interpolée de la pluie (mm/h)

RR = Rainfall rate (mm/h) / Intensité de la pluie (mm/h)

T = Rainfall duration (h) / Durée de la pluie (h)

Statistics/Statistiques	2	5	10	25	50	100
	yr/ans	yr/ans	yr/ans	yr/ans	yr/ans	yr/ans
Mean of RR/Moyenne de RR	36.8	48.3	55.9	65.5	72.7	79.8
Std. Dev. /Écart-type (RR)	36.4	47.5	54.8	64.0	70.8	77.6
Std. Error/Erreur-type	8.8	11.2	12.7	14.7	16.2	17.7
Coefficient (A)	21.7	28.9	33.6	39.6	44.0	48.4
Exponent/Exposant (B)	-0.707	-0.698	-0.695	-0.692	-0.690	-0.688
Mean % Error/% erreur moyenne	7.5	7.8	7.9	8.1	8.1	8.2