

SUBJECT: Access to County Roads Policy

1.0 BACKGROUND

The primary function of the County Road system is to permit the safe and efficient movement of **through traffic** over relatively long distances at reasonable speeds. This important function is diminished where uncontrolled development adjacent to the road creates turning and stopping movements which interfere with the free flow of traffic.

A secondary function of the County Road system is to provide access to properties at appropriate locations consistent with road safety. Too many accesses may lead to speed reductions and hazards to through traffic movements resulting in the deterioration of service levels. Therefore, to maintain the integrity of the system, **entrances to County Roads will be permitted only when access from local municipal roads to the property is not feasible.**

Since accesses to County Roads have long-term and cumulative effects on the road network a process to oversee the construction of new entrances or the alteration of existing entrances is essential.

The purpose of this policy is to establish the specifications and procedures for the submission, review, site inspection and approval of County Road entrance applications. The objective of the policy is to balance the two major functions of the County Road system; moving traffic and providing access to properties, while:

- a) Protecting the safety of all roadway users through the orderly control of traffic movements.
- b) Encouraging and fostering growth and development throughout the County within the context of the local municipal Official Plans and Zoning By-Laws.
- c) Protecting the public investment in the County Road System.
- d) Ensuring that all new developments have suitable and legal access.
- e) Minimizing future road maintenance and construction costs.

2.0 DEFINITIONS

“Agricultural Entrance” Means a farm or field entrance.

“Alter Existing Entrance” Means changing the surface, the width or the culvert of an existing entrance without changing the type of entrance.

“Applicant” Means any person, group or corporate body who applies to the Corporation for permission to construct, relocate or alter an entrance to a County Road.

“Built-Up Area” Areas of concentrated development; including: towns, hamlets, villages and settlement areas, or any other area shown in Schedule A

“Common Entrance” Provides access to two (2) properties when individual entrances are not feasible due to physical constraints or inadequate spacing between adjacent entrances. The entrance is normally constructed astride the property line, but may be located in another location, if the approval to utilize the right of way approval process is obtained from the appropriate planning authorities. The approval of both property owners is mandatory prior to the construction

SUBJECT: Access to County Roads Policy

of a common entrance.

“Commercial/Industrial/Institutional” Provides access to: a location where goods are manufactured, stored, or sold,; institutional areas such as schools, religious facilities and hospitals,

“Culvert” An open-ended, underground pipe that carries surface storm water under a road or entrance.

“Director” The County of Lanark Director of Public Works or in his absence his designate.

“Entrance” A private road, entranceway, gate or other structure or facility constructed or used as a means of access to a County Road. Entrances are classified in accordance with their use and the approved zoning of the property. For example a property must be zoned as Commercial to permit the construction of a commercial entrance.

“Farm Entrance” Provides access to farm buildings and agricultural lands, but does not include commercial activities related to agriculture such as abattoirs, tanneries and sales outlets, or storing, manufacturing and processing activities involving farm crops or animal products.

“Field Entrance” Provides access to agricultural fields forming part of a farm or to woodlots. Used only for the passage of animals and crops or vehicles related to the harvesting of timber, but not for access to buildings of any type.

“Highway” Includes a common and public highway and any bridge, trestle, viaduct or other structure, forming part of the highway, and except as otherwise provided, includes a portion of the highway and the area between the lateral property lines thereof. All County Roads are included in this definition.

“In-Filling” In the past small concentrations of development, generally residential, occurred in certain locations in the form of strip or ribbon development along rural roadways. This development generally predated the establishment of Official Plan and Zoning By-law controls within local municipalities. For the purpose of this policy, “In-filling” will be considered as the use of vacant land within the area of concentrated development, for further construction or development, **but not extending the limits of the concentrated development.**

“Intersection” The area within the projection or connection of the lateral boundary lines of two (2) or more highways that meet one another at an angle whether or not one highway crosses the other.

“Inquiry” A request to the Public Works Department by a prospective property buyer or their agent to determine if an Entrance Permit for an existing entrance has been issued or if the installation of a new entrance is feasible.

“Lot” A parcel or tract of land which is capable of being legally conveyed in accordance with the provisions of the Planning Act.

“Minor Exemption” Entrance locations and configurations, that do not meet the policy, not including safety requirements, may be approved at the sole discretion of the Director of Public Works.

“Multi-Residential” A residential entrance providing access to residential facilities of two or more dwellings such as Additional Residential Units (ARU's), apartments and townhouse

ISSUED BY:	DATE ISSUED:	SUPERCEDES:	PAGE:
County Council	June 12, 2024	November 13, 2019	2 of 25

SUBJECT: Access to County Roads Policy

developments.

“One-Way Entrance” An entrance that provides access to a County Road and is designed or used for one-way traffic only.

“Other Entrance” An entrance that provides access, or additional access, and that does not fit any other entrance type defined under this policy. May be also referred to as an auxiliary entrance.

“Pedestrian Entrance” Provides pedestrians access from a trail or pathway across a County Road.

“Percent (%) Grade” Means the rate of rise or fall with respect to the horizontal.

“Posted Speed” The maximum speed for vehicles as indicated by the regulatory signs posted on the roadway. Where the posted speed changes within the prescribed sight distance for an entrance, the higher posted speed shall be used to determine the minimum sight distance.

“Private Road Entrance” Provides access to a County Road from a private right of way that is not maintained by the local municipality. Includes sub-division roads, until they have been assumed by the municipality.

“Property Line” The common boundary line between adjacent properties.

“Public Road Entrance” Provides access to a County Road from a municipal road or street or other thoroughfare that is maintained by the local municipality.

“Residential Entrance” Provides access to a residential property.

“Rural Road Section” means a County road section located outside the boundaries of a built-up area. A rural road has the primary function of providing access to rural and/or rural residential properties.

“Shared Entrance” A entrance providing access to two adjacent lots, that can be any combination of the following entrance types: Farm, Field, Residential, and/or Commercial/Industrial/Institutional.

“Sight Distance” The minimum stopping sight distance is the least available distance required for a driver to bring a vehicle travelling at or near the posted speed to a stop before reaching a visible stationary object in its path. It is the sum of perception distance, reaction distance and braking distance under wet road conditions

“Single Residential” A residential entrance providing access to a single residential dwelling.

“Temporary Entrance” Provides access to a property for a limited period, not to exceed one (1) year, for the purpose of construction, repairs or improvements on that property or to facilitate a staged development. The temporary entrance must be removed before the expiration of the permit and the right-of-way must be restored to its original condition.

“Urban Entrance” An entrance that is located within the limits of an urban County Road section. An urban road section is any portion of a County Road that is constructed with any of the following features; curb, gutter, sidewalk or storm sewer.

ISSUED BY:

County Council

DATE ISSUED:

June 12, 2024

SUPERCEDES:

November 13, 2019

PAGE:

3 of 25

SUBJECT: Access to County Roads Policy

“**Urban Road Section**” means a County road section located within the boundaries of a built-up area. Urban roads are typically characterized by the presence of street lighting and in most but not all cases the presence of curb and gutter.

“**Vehicle**” Includes a motor vehicle, trailer, traction engine, farm tractor, road building machine, bicycle and any vehicle drawn, propelled or driven by any kind of power, including muscular power, but does not include a motorized snow vehicle or street car.

3.0 FEES

Non-refundable application fees, as described in Schedule “D”, must accompany each entrance application. Fees shall be payable in cash, by cheque payable to the County of Lanark, Interact Debit, or electronic transfer.

Fees will be waived for entrance applications submitted by local municipalities in the County of Lanark and not-for-profit organizations as approved by the Director.

The entrance application fees will be subject to annual review and revision by Council as they deem appropriate.

4.0 TYPE & LOCATION

Type of Entrance

Entrance types governed by this policy as defined in “2.0 – DEFINITIONS” are as follows:

- Farm
- Field
- Residential (Single/Multi)
- Commercial/Industrial/Institutional
- Road (Public/Private)
- Temporary
- Shared
- Other

All entrances applied for must be of a type consistent with the permitted use of the land being accessed, as described by the local municipal official plan and/or zoning by-law.

Location of Entrance

Road safety, road efficiency and local site condition criteria must be satisfied before access to a County Road will be permitted.

Road Safety Criteria

Stopping Sight Distance

All new entrances must provide unobstructed sight distance, in **both** directions as shown in the following table. When braking occurs on a downgrade, the effect of the grade is to increase braking distance. Conversely, on an upgrade the effect is to reduce the braking distance. Therefore the minimum stopping sight distance is adjusted for entrances on County Roads where the grade exceeds 3 percent over the course of the braking distance. For the purposes of this

ISSUED BY:

DATE ISSUED:

SUPERCEDES:

PAGE:

County Council

June 12, 2024

November 13, 2019

4 of 25

SUBJECT: Access to County Roads Policy

policy the County has adopted the Minimum Stopping Sight Distances defined in the Ontario Good Roads Association Geometric Guidelines for Municipal Roads 1998.

The measurement of minimum sight distances shall be in accordance with the following standards:

- a. The driver’s eye level is defined as 1.05 metres above ground.
- b. The height of object (vehicle headlights) is defined as 0.65 metres above the road surface.
- c. For vehicles accessing the county road, visibility is measured from the driver’s eye level, at a point set back 3 metres from the edge of pavement.

County Road Posted Speed (kilometres per hour)	Minimum Stopping Sight Distance m=metres ft=feet				
	Grade of County Road less than 3 %	Grade of County Road greater than 3 %			
		Upgrade		Downgrade	
		Greater than 3% but less than 6%	6% or greater	Greater than 3% but less than 6%	6% or greater
80	160 m/525 ft	150 m/492 ft	140 m/459 ft	170 m/558 ft	200 m/656 ft
70	135 m/443 ft	125 m/410 ft	120 m/394 ft	145 m/476 ft	165 m/541 ft
60	110 m/361 ft	105 m/344 ft	100 m/328 ft	115 m/377 ft	130 m/426 ft
50	85 m/279 ft	80 m/262 ft	80 m/262 ft	90 m/295 ft	100 m/328 ft
40	65 m /213 ft	60 m/197 ft	60 m/197 ft	65 m/213 ft	75 m/246 ft

Example: A new entrance to a County Road in an 80 kph (kilometres per hour) posted speed zone where there is a 6 percent grade must have a minimum sight distance of 140 metres (459 feet) in the direction downgrade from the entrance and 200 metres (656 feet) in the direction upgrade from the entrance.

Improvement of Sight Distances: Where the minimum required sight distances cannot be met without the removal of brush, rock cuts or other obstructions, the applicant may request permission to remove the obstructions, at no cost to the County. Such removals will normally be accomplished by a contractor retained by the owner and in accordance with the written specifications of the Director. If the Director stipulates that the work must be undertaken by County forces the applicant must provide a cheque or cash for the total estimated cost of the work, before the work begins.

Proximity to Bridges and Structures

Structures such as bridges may obstruct the vision of traffic using an adjacent entrance and traffic on the County Road approaching the entrance. Therefore entrances shall be located as shown in the table below:

SUBJECT: Access to County Roads Policy

Posted Speed (kph)	Entrance Type	Minimum Distance to Structure (m)
60 to 80	All	50
50 or less	All	As specified by the Director

Proximity to Intersections

On rural road sections entrances shall not be permitted within 50 metres of the intersection of a County and public or private road, regardless of the posted speed. Where possible, access to properties with frontage on a County and public/private road shall be from the public/private road.

Unless otherwise indicated, the distance between intersections shall be measured from the centre of the entrance to the centre of the intersection.

Proximity to Public/Private Roads

New roads resulting from Plans of Subdivision shall be permitted to intersect with a County Road at a distance of not less than 300 metres from an existing or proposed intersection onto a rural County Road section.

Proximity to Acceleration, Deceleration or Passing Lanes

On rural road sections entrances must be located at least 50 metres from acceleration, deceleration or passing lanes.

Road Efficiency Criteria

Proximity to Adjacent Entrances

For the purposes of this policy the **rural road sections** of the County Road system are divided into five groups based upon the following major considerations: traffic volume, type of traffic and the nature of the road. Spacing of all entrance types, except Field, Farm, Temporary, Commercial/Industrial/Institutional/ shall be as described in Schedule "B".

On **urban road sections**, in towns, villages, hamlets and settlement areas, one (1) residential entrance per lot shall be permitted.

In **built-up areas** that are not designated as towns, villages, hamlets or settlement areas, residential entrances will be permitted only where the need for the entrance is as a result of "in-filling" and the mandatory road safety criteria are met. Residential entrances which **extend the limits of existing urban or built-up areas** shall not be permitted. Built up areas are listed in Schedule "A".

Spacing of **Commercial/Industrial/Institutional** shall be subject to site plan review and approval by the Director.

Unless otherwise indicated, the distance between an adjacent entrance shall be measured from the centre of the adjacent entrance.

The spacing of adjacent entrances will be subject to review and revision by Council as they deem

ISSUED BY:

County Council

DATE ISSUED:

June 12, 2024

SUPERCEDES:

November 13, 2019

PAGE:

6 of 25

SUBJECT: Access to County Roads Policy

appropriate.

Local Site Conditions

Above and Below Ground Utilities

It is the applicant's responsibility to locate all underground utilities prior to the installation of their entrance. If utility poles, wires or other fixtures on the road allowance must be removed or relocated to accommodate the applicant's entrance, the cost of all such work shall be borne by the applicant. Coordination of such work with the applicable utility shall be the applicant's responsibility.

Number of Entrances

The number of entrances permitted will be the minimum necessary to accommodate the needs of each development. Multiple entrances shall only be approved where a single entrance would not provide reasonable access. Entrances will be assessed on a case by case basis and if justified may be permitted at the discretion of the County.

A Traffic Impact Study completed by the Developer shall be considered by the Director when determining the number of entrances required for Commercial, Industrial, Institutional and Multi-Residential Entrances.

- *Residential Entrances:* Only one (1) entrance per residential lot shall be permitted
- *Farm Entrances:* Only one (1) entrance per farm property shall be permitted.
- *Field Entrances:* No more than three (3) field entrances to a property shall be permitted.

5.0 ADMINISTRATION

Entrance Inquiries

A prospective property buyer or their agent may inquire if an Entrance Permit has been issued for an *existing* entrance. The Public Works Department will complete the necessary file search, at no cost, and respond within two (2) working days of receiving the inquiry.

Questions by prospective property owners or their agents regarding the possible location of *new* entrances will not be considered by Department staff until an Entrance Inquiry Application has been submitted with a non-refundable \$100 fee. Upon receipt of the application and fee Public Works Department staff shall visit the site and respond to the inquiry within ten (10) working days. In any case an Entrance Application, as described below, must be submitted if the property is ultimately purchased by the prospective buyer. The \$100 Entrance Inquiry fee will be deducted from the Entrance Application fee, if the full Entrance Application is submitted within one year of the Inquiry Application.

Entrance Application Process

Entrance applications **will not be approved** when winter conditions make site inspections impossible.

Submission Requirements: All requests to construct new entrances or to alter or close existing entrances on County Roads shall be submitted, on the appropriate application forms, to the County Public Works Department. One (1) application shall be submitted for each entrance and fees are payable for each entrance application. Requests shall include:

ISSUED BY:	DATE ISSUED:	SUPERCEDES:	PAGE:
County Council	June 12, 2024	November 13, 2019	7 of 25

SUBJECT: Access to County Roads Policy

- i) Completed Entrance Application
- ii) Registered Plan of property
- iii) Application fee

If a plan of the property is not available a detailed sketch with the appropriate dimensions must be submitted with the application.

Application Review: Applications will be reviewed by County staff for completeness and compliance with the policy. The County review process will not begin until receipt of a complete application package, as described above. Other than commercial/industrial/institutional applications, the application process for entrances that comply with the County policy will, under normal circumstances, not exceed twenty business days from the date that the completed application is received until the approval to install the entrance is granted. Changes to the application by the applicant during the review process will increase the length of the review period. If the entrance application forms part of a planning application (upper or lower tier application), the applicant shall demonstrate that the configuration/application for entrances is in conformity with all relevant planning policies at the upper and lower tier municipalities. Under normal circumstances, the application approval process for commercial/industrial/institutional applications shall not exceed thirty business days from the date that the site plan is received.

First Site Inspection: A site inspection by Public Works staff shall normally be performed within 10 working days of receipt of the application. The site inspection shall determine if the application conforms to the County policy; the size, type, and location of the culvert required to ensure proper road drainage and the requirement for curb cuts, brushing or other work.

Non-Conforming: If the proposed location does not conform to the County Policy, the County will provide alternative locations. The Director of Public Works may approve a “**minor exemption**” entrance, allowing for minimal deviations to the location criteria . Minor exemptions only include location requirements and do not include safety such as stopping sight distance.

Application Approval: Applicants will be notified in writing when their application has been approved. Notification shall include the Entrance Design Specification.

Installation: The owner may engage a contractor to complete the work. The entrance shall be installed in accordance with the Design Specification and all conditions.

No work shall commence until the contractor/individual completing the installation obtains a “Work in Right-of-Way” permit from the County.

Removal of Redundant Entrances: Redundant entrances that are created as a result of the approval of a new entrance application shall be removed and reinstated as specified by the Director. In urban road sections reinstatement may include the installation of curb and gutter, sidewalk and boulevard to conform to the existing conditions. Removal of existing entrances and reinstatement will be completed coincident with the installation of the new entrance, at the owners cost, as specified in the Entrance Design Specification. The owner/contractor deposit shall not be returned until all such removals and reinstatement have been completed.

Final Inspection: The owner shall inform the Public Works Department immediately after the installation of the entrance and the completion of any other work stipulated in the Design Specification. The Public Works Department shall inspect the site within five working days of receiving notification of completion. If the inspection is not successful the County shall notify the

SUBJECT: Access to County Roads Policy

owner of the deficiencies to be remedied in accordance with “Non- Compliance with the Policy” paragraph below.

Permit Issuance: Within five working days of a successful final inspection of the site by the Public Works Department, the Entrance Permit will be provided to the applicant.

The owner should retain the Entrance Permit to ensure that it is available to future owners of the property.

Denial of Entrance Application

Entrance applications that do not conform to this policy shall be denied and the applicant shall be so informed in writing within five days of the Director’s decision.

If the entrance has been denied because of proximity to an adjacent entrance (ie. Insufficient spacing) the applicant may request to appear before the County Public Works Committee at their monthly meeting. Such requests must be received by the Director at least two (2) weeks prior to the scheduled meeting and include a written summary of the applicant’s presentation to the Committee. The applicant’s summary shall be distributed to the Committee members with the Agenda. The applicant’s verbal presentation to the Committee shall be no longer than ten minutes. The Director shall prepare a report with recommendations regarding the applicant’s presentation for the next scheduled meeting of the Committee. The Committee’s recommendation shall then be considered by County Council. The Director shall inform the applicant in writing of Council’s decision as soon as possible.

Severances

Where an application for severance is made on a County Road on which the right-of-way has not been widened to the standard limits, the Public Works Department may request the conveyance of the said widening as a condition of granting of the severance. The conveyance of property for future road widening purposes may be required on both the severed and retained parcels. Sight triangles on parcels adjacent to existing public or private roads may also be required as a condition of severance. Also the dedication of a 0.3 metre reserve along the frontage of the severed and/or the retained parcel may be required as a condition of severance approval.

Subdivisions

Plans of Subdivision with frontage on County Roads may include public roads to provide access to the Subdivision internal street network. The Developer shall undertake a Traffic Impact Assessment, at no cost to the County, to determine the traffic implications and requirements of the development. Such requirements may include the installation of traffic signals, street lights, road signs, left turn lanes, right turn deceleration lanes, curb and gutter and the provision of storm drainage or other road works to ensure an adequate level of service on the County Road.

Cancellation of Application

Where the entrance has not been constructed within one (1) year of the date of the application, then the application shall be null and void. A written request to extend the term of the application may be made to the County Public Works Department before the application expires. An extension may be approved or refused at the discretion of the Director. If the application expires the County may request the removal of all works associated with the entrance, at no expense to the County, and the site shall be restored to its original condition.

Non-Compliance with the Policy

ISSUED BY:	DATE ISSUED:	SUPERCEDES:	PAGE:
County Council	June 12, 2024	November 13, 2019	9 of 25

SUBJECT: Access to County Roads Policy

Where a new entrance is constructed or an existing entrance is altered contrary to the standards contained herein, the property owner shall be advised of their non-compliance with the County policy by registered letter. Removal or correction of the non-compliant entrance shall occur not less than ten (10) business days after this notification. If the non-compliant entrance is not removed or corrected the contractors deposit shall be forfeited via the "Work in Right-of-Way" permit, and the entrance shall be removed or corrected by the County Public Works Department. Should the costs to the County exceed the deposit, the balance of the cost shall be charged to the property owner. If no deposit has been received the total cost of the entrance removal will be charged to the property owner. The property owner shall not be entitled to any compensation or damages by reason of or arising out of the work associated with the non-compliant entrance. If necessary, the Director may request that the local municipality include any balance owing to the County on the owner's property tax bill.

Denial of Access

Existing lots that do not have an existing entrance will not be denied access. If the proposed entrance location does not meet the requirements of this policy, the County will determine the safest location and all reasonable efforts will be made to improve safety at the owners expense under the approval to the Director of Public Works.

The Director of Public Works shall, in his sole discretion, determine the placement of the entrance and all works (including signage) required to improve the safety of the entrance.

The Director of Public Works may request an Agreement with the landowner in respect to the entrance, which Agreement may include, but not be limited to, items such as:

- a. Insurance.
- b. indemnification of County.
- c. maintenance of entrance and any signage required.
- d. costs of the Agreement.

The Warden and Clerk are authorized, in the name of County, to execute the said Agreement or any other documents as may be required in order to give effect to the said Agreement.

Maintenance of Entrances

Residents having access to a County road are fully responsible for the maintenance of the entrance to their property. Maintenance includes but is not limited to the removal of snow and ice, shoulder gravel and winter sand. During the winter the County will not clear entrance culverts that have become blocked as a result of improper snow disposal by the resident. Culverts that collapse deteriorate or become unsuitable for proper drainage shall be replaced by the property owner at their expense. If necessary the Director may request that the local municipality include any costs incurred by the County Public Works Department to correct the problem on the owner's property tax bill.

Road Reconstruction/Rehabilitation

Existing entrances that are affected by the reconstruction/rehabilitation of a County Road will be reinstated by the County. Any construction materials that are salvaged shall remain the property of the County.

6.0 ENTRANCE DESIGN SPECIFICATIONS

ISSUED BY:

County Council

DATE ISSUED:

June 12, 2024

SUPERCEDES:

November 13, 2019

PAGE:

10 of 25

SUBJECT: Access to County Roads Policy

All works related to or forming a part of an approved entrance shall be carried out in accordance with the following specifications:

Entrance Configuration: Shall conform to the designs shown at Schedule “C” for the type and location of entrance to be constructed.

Entrance Angle of Approach: The entrance shall as nearly as practicable intersect the County Road at 90 degrees. In exceptional circumstances, the Director may authorize an intersection of not less than 70 degrees.

Entrance Grade: Entrances must be designed, constructed and maintained to ensure that surface water from the adjoining property is not discharged onto the County Road, unless storm sewer drainage is available. Entrance Grade will be as per the Entrance specification provided at the time of approval.

Surface Type and Width: Shall be as specified below for each type of entrance. The use of concrete or paving stones within the right-of-way is prohibited. The County will not be responsible for damage done to the portion of a driveway within the right-of-way if it has been changed or altered in any way.

Field Entrance: Shall be surfaced with a least 100 mm (4”) crushed gravel (Granular “A”). Entrances will have a minimum entrance width of 5 metres. Entrances wider than 10 metres will not be permitted.

Residential Entrance: Shall be surfaced with a least 150 mm (6”) crushed gravel (Granular “A”). At the property owner’s option a 50 mm thickness of asphalt HL3 may be placed on that portion of the entrance within the right-of-way. Entrances of this type will normally have a minimum entrance width of 5 metres.

Commercial/Industrial/Institutional: Entrances of this type will be of a surface type to meet the requirements of the number and types of vehicles using the entrance. In many instances this may require a minimum of 50 mm of asphalt HL3 over 150 mm of crushed gravel. Entrances of this type will normally not be less than 8 metres in width. Entrances shall be designed in accordance with the Ministry of Transportation “Commercial Site Access Policy and Standard Designs.” All such entrances shall be reviewed on a case by case basis and if appropriate, approved by the Director.

Private and Public Roads: Shall conform to the development standards of the municipality in which the development is situated.

Curb and Gutter: Where curb and gutter exists at the location of the proposed entrance, the applicant will be required to construct a curb cut at the entrance location. The existing curb shall be removed and replaced using material acceptable to the Director or altered in accordance with the Director’s requirements. The area between the curb and sidewalk is to be paved with a minimum 50 mm thickness of asphalt HL3. If there is no sidewalk, the entrance is to be paved to the property line.

Culverts: The diameter of a culvert must be sufficient to maintain the free flow of water in the ditch. The length of the culvert is determined by the width of the entrance plus the width of the slopes on both sides of the entrance, as measured from the bottom of the ditch. The culvert length and size will be determined by the County of Lanark and provided as part of the specification.

ISSUED BY:

DATE ISSUED:

SUPERCEDES:

PAGE:

County Council

June 12, 2024

November 13, 2019

11 of 25

SUBJECT: Access to County Roads Policy

Curb and/or Headwalls: No curb or headwall shall extend above the surface of the roadway shoulder within a distance of 4 metres from the edge of the pavement.

Catch Basins: When a culvert in excess of 12 metres in length is required, the applicant shall be required to pay the entire cost of construction of as many catch basins, inlet or outlet structures as may be necessary, in the opinion of the Director, to facilitate surface drainage from or along the side of the roadway.

7.0 LIST OF SCHEDULES

- Schedule A- Built up Areas
- Schedule B- Spacing of Entrances
- Schedule C- Entrance Configuration
- Schedule D- Fee's

SUBJECT: Access to County Roads Policy

SCHEDULE A: BUILT-UP AREAS

Built Up Areas Outside Town/Hamletr Boundaries							
CR#-Rd Name	Location Description	Asset ID	Municipality	Urban Extension	Lane	From	To
1-Rideau Ferry Rd.	Chaloe Acres	001065	DNE	No	Both	PIN 2405	PIN 2643
4-Roger Stevens Dr	Montague/Nolans Corners	004011	Montague	No	Both	PIN 6514	PIN 6818
6-Christie Lake Rd	Glen Tay East	006231	Tay Valley	No	EBL	PIN 389	PIN 563
16-South Lavant Rd	Lavant Station	016000	Lanark Highlands	No	Both	PIN 5240	PIN 5329
16-South Lavant Rd	Robertson Lake North Shore	016052	Lanark Highlands	No	Both	PIN 4155	PIN 4189
16-South Lavant Rd	Poland	016153	Lanark Highlands	No	Both	PIN 2244	PIN 2298
17-Cemetery Side Rd	Queensway West	017072	Beckwith	No	NBL	PIN 2463	Hemlock Dr
				No	SBL	PIN 2463	St Fillans Rd
23-Rosedale Rd	Rosedale	023028	Montague	No	Both	PIN 678	PIN 785
36-Elphin Maberly Rd	Izatt Lake	036291	Lanark Highlands	No	Both	PIN 3861	Adams Rd
43-Hwy 43	Edmonds Locks	043086	Smiths Falls	No	Both	PIN 2967	PIN 3032
43-Hwy 43	Poonamalie	043144	DNE	No	Both	PIN 3816	PIN 3863
43-Hwy 43	The Pines	043144	DNE	No	EBL	Pine Ave	PIN 4838
9-Tatlock Rd	Clayton	009129	Mississippi Mills	Yes	Both	Boundary	PIN 2733
4-Roger Stevens Dr	Smiths Falls	004000	Montague	Yes	Both	Boundary	Code Dr

ISSUED BY:

County Council

DATE ISSUED:

June 12, 2024

SUPERCEDES:

November 13, 2019

PAGE:

13 of 25

SUBJECT: Access to County Roads Policy

Towns and Hamlets (Follows Township's OP Boundary)			
CR#-Rd Name	Location Description	Asset ID	Municipality
6-Christie Lake Rd	Dewitt's Corners	006172	Tay Valley
7B-Townline Rd.	Carleton Place	007900	CP
8-Watsons Corners Rd	Watson's Corners	008102	Lanark Highlands
9-Tatlock Rd	Clayton	009129	Mississippi Mills
10-Perth Rd	Gillie's Corners	010350	Beckwith
10-Perth Rd	Franktown	010398	Beckwith
12-McDonalds Crnrs. Rd.	McDonald's Corners	012079	Lanark Highlands
12-Markle Rd - Mill St - South St - Pine Grove Rd	Lanark Village	012236	Lanark Highlands
17-Martin St North - Blakeney Rd	Blakeney	017284	Mississippi Mills
29-McNeely Avenue - Townline Rd	Carleton Place	029000	CP
1-Rideau Ferry Rd.	Rideau Ferry	001000	DNE
4-Roger Stevens Dr	Smiths Falls	004000	Montague
6-Christie Lake Rd	Glen Tay	006231	Tay Valley
7-Fallbrook Rd	Balderson	007000	Tay Valley
7-Fallbrook Rd	Fallbrook	007062	Tay Valley
8-6th Con. C Lanark	Middleville	008224	Lanark Highlands
10-Scotch Line & South St	Perth	010157	Town of Perth
10-Richmond Rd	Prospect	010497	Beckwith
11-Wilson St & River Rd	Appleton	011015	Mississippi Mills
12-McDonalds Crnrs. Rd.	Elphin	012000	Lanark Highlands
15-Fergusons Falls Rd	Ferguson's Falls	015086	Lanark Highlands
16-Wolf Grove Rd	Hopetown	016247	Lanark Highlands
16-Almonte St	Almonte	016494	Mississippi Mills
16A - Perth St - Bridge St - Queen St - Martin St S	Almonte	016900	Mississippi Mills
18-Port Elmsley Rd	Port Elmsley	018053	DNE
20-Waba Rd	Pakenham	020021	Mississippi Mills
29-Christian St	Almonte	029123	Mississippi Mills
29-County Rd. #29 North	Pakenham	029275	Mississippi Mills
36-Bolingbroke Rd- Maberly Elphin Rd	Maberly	036140	Tay Valley
36-Elphin Maberly Rd	Elphin	036280	Lanark Highlands
43-Hwy 43	Port Elmsley	043221	DNE
511-Lanark Rd - Hwy 511	Perth	511000	Town of Perth
511-Hwy 511	Balderson	511067	DNE/Tay Valley

ISSUED BY:

County Council

DATE ISSUED:

June 12, 2024

SUPERCEDES:

November 13, 2019

PAGE:

14 of 25

SUBJECT: Access to County Roads Policy

SCHEDULE B: SPACING OF ENTRANCES

AADT Range	Min. Spacing	Group
0 -600	50m	B
601 - 2999	100m	C
3000 - 6999	150m	D
7000 +	200m	E

ROAD NAME	FROM:	TO:	Km	ASSET #	AADT	SPD	M N CL	LOW TIER	GROUP
1-Rideau Ferry Rd.	Leeds Bndry	Yacht Club Road	0.5 1	00100 0	3200	60	3	DNE	D
1-Rideau Ferry Rd.	Yacht Club Road	Port Elmsley Rd. (CR 18)	1.9 1	00100 5	3200	80	3	DNE	D
1-Rideau Ferry Rd.	Port Elmsley Rd. (CR 18)	Elmgrove Rd (CR 21)	2.1 2	00102 4	3500	80	3	DNE	D
1-Rideau Ferry Rd.	Elmgrove Rd (CR 21)	Millar Brooke Way	1.9 8	00104 5	4200	80	3	DNE	D
1-Rideau Ferry Rd.	Millar Brooke Way	Wild Life Road	2.2	00106 5	4200	70	3	DNE	D
1-Rideau Ferry Rd.	Wild Life Road	South Street (CR 10)	1.7 2	00108 7	6500	70/6 0	3	DNE/P	D
2-Heritage Drive	Merrickville Bndry	Gilroy Road (Ottawa Bndry)	4.9	00200 0	1750	80	3	MON	C
4-Roger Stevens Drive	Rideau Avenue	Code Drive	1.0 8	00400 0	5000	60	3	MON	D
4-Roger Stevens Drive	Code Drive	Rosedale Rd. S (CR 23)	4.4 1	00401 1	3900	80	3	MON	D
4-Roger Stevens Drive	Rosedale Rd. S (CR 23)	Fletcher Road	7.8 3	00405 5	3900	80	3	MON	D
4-Roger Stevens Drive	Fletcher Road	Montague Bndry Rd (Ottawa Bndry)	4.2 8	00413 4	3000	80	3	MON	D
6-Althorpe Road	Bolingbroke Road (CR 36)	Hanna Road	6.7 9	00600 0	400	80	4	TVT	B
6-Althorpe Road	Hanna Road	Christie Lake North Shore Road	7.3 8	00606 8	800	80	4	TVT	C
6-Christie Lake Road	Christie Lake North Shore Road	Cameron Side Road	2.8 4	00614 3	1250	80	3	TVT	C
6-Christie Lake Road	Cameron Side Road	PIN #1940 (Dewiits Corners)	0.7 6	00617 2	1700	60	4	TVT	C
6-Christie Lake Road	PIN #1940 (Dewiits Corners)	PIN #910 (Glen Tay)	5.0 3	00617 8	1700	80	3	TVT	C
6-Christie Lake Road	PIN #910 (Glen Tay)	PIN #793 (Glen Tay)	0.5 6	00623 1	2800	60	4	TVT	C
6-Christie Lake Road	PIN #793 (Glen Tay)	County Admin. Entrance	3.6	00623 7	2800	80	3	TVT	C
7-Fallbrook Road	Hwy 511 (CR 511)	Balderson Hamlet Sign	0.2 7	00700 0	2000	60	4	TVT	C
7-Fallbrook Road	Balderson Hamlet Sign	Fall Crescent (North)	5.9	00700 2	2000	80	3	TVT	C
7-Fallbrook Road	Fall Crescent (North)	Bennett Lake Rd. (CR 19)	0.4 6	00706 2	1500	50	4	TVT	C
7-Fallbrook Road	Bennett Lake Rd. (CR 19)	MacKay Line	0.2 9	00706 7	1500	50	4	TVT	C
7-Fallbrook Road	MacKay Line	McDonalds Corners Rd (CR 12)	1.5 7	00707 0	1500	80	3	TVT	C
7B-Townline Rd. West	Hwy. #7	PIN #267 (Mississippi Mills Bndry)	1.2 5	00790 0	3500	60	3	BCK/MM	D
7B-Townline Rd. West	PIN #267 (Mississippi Mills Bndry)	Bridge Street	0.8 6	00791 2	7400	50	3	CP	E
7B-Townline Rd. East	Bridge Street	McNeely Ave. (CR 29)	1.1 4	00792 1	8350	40/5 0	3	CP	E

ISSUED BY:

County Council

DATE ISSUED:

June 12, 2024

SUPERCEDES:

November 13, 2019

PAGE:

15 of 25

SUBJECT: Access to County Roads Policy

8-Watsons Corners Road	McDonalds Corners Rd. (CR 12)	Hollie Drive	0.7 6	00800 0	620	50	4	LH	C
8-Watsons Corners Road	Hollie Drive	PIN #2607 (Watsons Corners)	8.8 8	00800 8	620	60/8 0	4	LH	C
8-Watsons Corners Road	PIN #2607 (Watsons Corners)	PIN #2462 (Watsons Corners)	0.7 3	00810 2	620	50	4	LH	C
8-Watsons Corners Road	PIN #2462 (Watsons Corners)	Hwy 511 (CR 511)	5.4 1	00810 4	900	80	4	LH	C
8-Herron Mills Road	Hwy 511 (CR 511)	6th Con. C Lanark (CR 8)	6.3 9	00816 0	450	80	4	LH	B
8-6th Con. C Lanark	Herron Mills Road (CR 8)	Wolf Grove Rd. (CR 16)	0.4	00822 4	500	60	5	LH	B
9-Tatlock Road	Hwy. #7	Wolf Grove Rd. (CR 16)	8.8 1	00900 0	1200	80	4	MM	C
9-Tatlock Road	Wolf Grove Rd. (CR 16)	PIN #2746 (Clayton)	3.8 3	00908 9	1200	80	3	MM	C
9-Tatlock Road	PIN #2746 (Clayton)	Bay Road	1.0 5	00912 9	1200	60	4	MM	C
9-Tatlock Road	Bay Road	Munro Line	5.0 9	00913 8	550	80	4	MM / LH	B
9-Tatlock Road	Munro Line	PIN #4277 (Halls Mills Bridge)	0.8 5	00915 2	550	80	4	LH	B
9-Tatlock Road	PIN #4277 (Halls Mills Bridge)	7th Con. Darling	6.7	00919 1	550	80	4	LH	B
9-Tatlock Road	7th Con. Darling	Hwy 511 (CR 511)	5.0 3	00926 7	400	60	5	LH	B
9A-McIlraith Road	Hwy 511 (CR 511)	4th Con Darling	0.3 9	00990 0	300	60	5	LH	B
10-Scotch Line	Leeds Bndry	Narrows Locks Rd. (CR 14)	8.4	01000 0	2000	80	3	TVT	C
10-Scotch Line	Narrows Locks Rd. (CR 14)	Otty Lake Side Road	7.2 6	01008 4	3500	80	3	TVT	D
10-Scotch Line	Otty Lake Side Road	PIN #2022 (Perth)	1.2 1	01015 7	6100	60	3	TVT/DNE	D
10-South Street	PIN #2022 (Perth)	Rideau Ferry Rd. (CR 1)	1.0 3	01017 0	6500	50	3	P	D
10-Drummond Con. 2	PIN #24 (Perth)	Spence Road	1.2 1	01019 2	3200	60	3	DNE/P	D
10-Drummond Con. 2	Spence Road	Richardson Side Road	5.9 9	01020 4	3200	80	3	DNE	D
10-Drummond Con. 2	Richardson Side Road	DNE/Beckwith Bndry (Day Rd.)	7.2 8	01026 4	3200	80	3	DNE	D
10-Perth Road	DNE/Beckwith Bndry (Day Rd.)	Gillies Corners Hamlet Sign West	1.3 9	01033 7	3300	80	3	BCK	D
10-Perth Road	Gillies Corners Hamlet Sign West	Gillies Corners Hamlet Sign East	1.8 5	01035 0	3300	60	3	BCK	D
10-Perth Road	Gillies Corners Hamlet Sign East	Franktown Hamlet Sign West	2.8 3	01036 3	3300	80	3	BCK	D
10-Perth Road	Franktown Hamlet Sign West	Hwy. #15	0.6 7	01039 8	3300	60	3	BCK	D
10-Richmond Road	Hwy. #15	Derry Side Rd. (CR 17)	6.1 4	01040 5	4200	80	3	BCK	D
10-Richmond Road	Derry Side Rd. (CR 17)	Crooked Side Road	3.1 9	01046 7	4200	80	3	BCK	D
10-Richmond Road	Crooked Side Road	Windmill Crescent	0.4 9	01049 7	4200	60	3	BCK	D
10-Richmond Road	Windmill Crescent	Ashton Station Road North	0.6 4	01050 0	4200	80	3	BCK	D
11-Wilson Street	CR 29 South	Appleton Hamlet Sign	1.3 4	01100 0	1200	60	4	MM	C
11-Wilson Street	Appleton Hamlet Sign	River Road	0.9 3	01101 5	1200	50	4	MM	C
11-River Road	River Road	Appleton Sideroad (CR 17)	0.9 8	01102 3	1050	60	4	MM	C
12-McDonalds Cmrs. Rd.	Elphin Maberly Rd. (CR 36)	2nd Con North Sherbrooke	1.3 1	01200 0	650	60 / 80	4	LH	C
12-McDonalds Cmrs. Rd.	2nd Con North Sherbrooke	Mill Avenue	6.4 4	01200 3	650	80	4	LH	C

ISSUED BY:

County Council

DATE ISSUED:

June 12, 2024

SUPERCEDES:

November 13, 2019

PAGE:

16 of 25

SUBJECT: Access to County Roads Policy

12-McDonalds Cmrs. Rd.	Mill Avenue	Watsons Cmrs. Rd. (CR 8)	0.8 8	01207 9	1000	50	4	LH	C
12-McDonalds Cmrs. Rd.	Watsons Cmrs. Rd. (CR 8)	McDonalds Corners Hamlet Sign	0.6 8	01208 8	1300	50	4	LH	C
12-McDonalds Cmrs. Rd.	McDonalds Corners Hamlet Sign	Fallbrook Rd. (CR 7)	8.9 6	01209 1	1300	80	3	LH / TVT	C
12-McDonalds Cmrs. Rd.	Fallbrook Rd. (CR 7)	PIN #2614 (Lanark Village)	5.2 5	01218 5	1000	80	4	TVT/DNE/LH	C
12-Markle Road	PIN #2614 (Lanark Village)	Argyle Street South	1.2	01223 6	1000	60	4	LH	C
12-Mill Street	Argyle Street South	George Street (CR 511)	0.3 7	01225 0	1000	50	4	LH	C
12-South Street	Hwy 511 (CR 511)	Roberts Road	0.6 5	01225 4	1450	50	4	LH	C
12-Pine Grove Road	Roberts Road	Lanark Village Sign	0.2 9	01226 0	1450	50	3	LH	C
12-Pine Grove Road	Lanark Village Sign	7th Con. A Lanark	5.2 2	01226 7	1450	80	3	LH	C
12-Pine Grove Road	7th Con. A Lanark	Fergusons Falls Rd. (CR 15)	4.6 4	01231 5	1200	70	4	LH	C
14-Narrows Lock Road	Leeds Bndry (Big Rideau North Shore)	Merkley Road (Days Corner)	2.3 6	01400 0	550	60	5	TVT/L&G	B
14-Narrows Lock Road	Merkley Road (Days Corner)	Lally Road (CR 21)	5.6 7	01402 4	350	60	5	TVT	B
14-Narrows Lock Road	Lally Road (CR 21)	Long Lake Road	3.3 6	01408 1	900	80	4	TVT	C
14-Narrows Lock Road	Long Lake Road	Scotch Line (CR 10)	5	01413 0	1100	80	4	TVT	C
15-Fergusons Falls Road	Hwy 511 (CR 511)	Drummond Con. 12B	8.5	01500 0	750	80	4	DNE	C
15-Fergusons Falls Road	Drummond Con. 12B	Ferguson's Falls Hamlet Sign East	1.5 1	01508 6	750	60	4	DNE	C
15-Fergusons Falls Road	Ferguson's Falls Hamlet Sign East	Pine Grove Rd. (CR 12)	0.5 7	01509 9	850	80	4	LH	C
15-Fergusons Falls Road	Pine Grove Rd. (CR 12)	Hwy. #7	4.9 5	01510 8	1300	80	3	LH	C
16-South Lavant Road	Frontenac Bndry	Morrison Lane	5.2	01600 0	150	60	5	LH	B
16-South Lavant Road	Morrison Lane	Lavant Mill Road	1.7 5	01605 2	150	40	5	LH	B
16-South Lavant Road	Lavant Mill Road	Umperson Mill Road	8.2 5	01607 0	200	60	5	LH	B
16-South Lavant Road	Umperson Mill Road	PIN #2264 (Poland)	0.5 6	01615 3	200	40	5	LH	B
16-South Lavant Road	PIN #2264 (Poland)	Hwy 511 (CR 511)	8.7 3	01615 8	350	80	4	LH	B
16-Wolf Grove Road	Hwy 511 (CR 511)	Hopetown Hamlet Limit (60 Max Sign)	0.3 7	01624 7	1300	60	4	LH	C
16-Wolf Grove Road	Hopetown Hamlet Limit (60 Max Sign)	PIN #4248 (Middleville)	3.7 6	01624 9	1100	80	3	LH	C
16-Wolf Grove Road	PIN #4248 (Middleville)	CR 8 (6th Con C Lanark)	0.1 6	01625 0	1300	60	4	LH	C
16-Wolf Grove Road	CR 8 (6th Con C Lanark)	PIN #4132 East Ent (Middleville)	0.4 2	01629 0	1400	60	4	LH	C
16-Wolf Grove Road	PIN #4132 East Ent (Middleville)	Ramsay Con 1	9.2 4	01629 2	1400	80	3	LH	C
16-Wolf Grove Road	Ramsay Con 1	Tatlock Road	1.4	01638 7	2000	80	3	MM	C
16-Wolf Grove Road	Tatlock Road	Civitan Hall Ent (Almonte)	9.2 5	01640 1	3000	80	3	MM	D
16-Almonte Street	Civitan Hall Ent (Almonte)	Christian Street (CR 29)	0.2 5	01649 4	3200	60	3	MM	D
16A-Perth Street	Christian Street (CR 29)	Bridge Street	0.3 1	01690 0	4500	50	3	MM	D
16A-Bridge Street	Perth Street	Centre of Maclan Bridge	0.9 8	01690 3	4500	50	3	MM	D
16A-Queen Street	Centre of Maclan Bridge	Martin Street South	0.2 7	01691 3	8000	50	3	MM	E
16A-Martin Street South	Queen Street	Ottawa Street		01691 6	8000	50	3	MM	E

ISSUED BY:

DATE ISSUED:

SUPERCEDES:

PAGE:

County Council

June 12, 2024

November 13, 2019

17 of 25

SUBJECT: Access to County Roads Policy

17-Derry Side Road	Richmond Road (CR 10)	9th Line Beckwith	7.2 1	01700 0	1200	80	4	BCK	C
17-Cemetery Side Road	9th Line Beckwith	Hwy. #7	2.9 4	01707 2	1200	50/7 0	3	BCK	C
17-Appleton Side Road	Hwy. #7	River Road (CR 11)	5.3 8	01710 1	800	80	4	BCK/MM	C
17-Appleton Side Road	River Road (CR 11)	March Road (CR 49)	7.3 5	01715 5	1100	80	3	MM	C
17-Martin Street North	Ottawa Street	Brookdale Street	0.6	01722 9	2200	50/4 0	4	MM	C
17-Martin Street North	Brookdale Street	Railway Crossing	2.2 1	01723 7	1100	80	3	MM	C
17-Martin Street North	Railway Crossing	PIN #6466 (Blakeney)	2.4 3	01725 9	1100	80	3	MM	C
17-Martin Street North	PIN #6466 (Blakeney)	Blakeney Road (CR 17)	0.4 8	01728 4	1100	60	4	MM	C
17-Blakeney Road	Blakeney Road (CR 17)	Ridge Road	0.6 1	01728 7	650	60	4	MM	C
17-Blakeney Road	Ridge Road	Panmure Road	1.5 2	01729 3	650	80	4	MM	C
17-Panmure Road	Blakeney Road (South)	Blakeney Road (North)	0.7 3	01730 8	400	80	4	MM	B
17-Blakeney Road	Panmure Road	Kinburn Sideroad (CR 20)	6.7 1	01731 5	300	80/6 0	4	MM	B
18-Port Elmsley Road	Rideau Ferry Road (CR 1)	PIN #310 DNE Township Office	4.6 2	01800 0	1250	80	3	DNE	C
18-Port Elmsley Road	PIN #310 DNE Township Office	CR #43	1.0 6	01805 3	1150	60	4	DNE	C
19-Bennett Lake Road	Fallbrook Road (CR 7)	PIN #155 (Fallbrook)	0.2 7	01900 0	450	50	5	TVT	B
19-Bennett Lake Road	PIN #155 (Fallbrook)	Osprey Road	8.9 7	01900 2	450	80	4	TVT	B
19-Bennett Lake Road	Osprey Road	Start of Gravel	4.3 5	01909 3	120	80	4	TVT	B
19-Bennett Lake Road	Start of Gravel	End of Gravel	2.3 7	01913 6	150	80	4	TVT	B
19-Bennett Lake Road	End of Gravel	Maberly Elphin Rd. (CR 36)	1.5 8	01915 6	150	80	4	TVT	B
20-Kinburn Side Road	Timmins Road (Ottawa Bndry)	Blakeney Rd. (CR 17)	1.4 8	02000 0	1900	80	3	MM	C
20-Kinburn Side Road	Blakeney Rd. (CR 17)	CR 29 North	0.6	02001 5	1900	60	4	MM	C
20-Waba Road	CR #29 North	Five Arches Drive	0.7 5	02002 1	1650	50	4	MM	C
20-Waba Road	Five Arches Drive	Shaw Road (CR 22)	5.1 8	02002 9	1650	80	3	MM	C
20-Waba Road	Shaw Road (CR 22)	Campbell Side Rd. (CR 24)	7.6 6	02008 1	1000	80	3	MM	C
20-Waba Road	Campbell Side Rd. (CR 24)	Robertson Line (Renfrew Bndry)	1.0 4	02015 8	1000	80	3	MM	C
21-Lally Road	Narrows Lock Rd. (CR 14)	Lally Lake Drive	5.1 9	02100 0	100	60	5	TVT	B
21-Elm Grove Road	Lally Lake Drive	Tay Valley Sign	6.8 7	02105 5	600	60	4	TVT	B
21-Elm Grove Road	Tay Valley Sign	Rideau Ferry Rd. (CR 1)	4.1	02112 3	1600	60	4	DNE	C
22-Shaw Road	Waba Road (CR 20)	Lunney Road (Ottawa Bndry)	2.6 9	02200 0	500	80	4	MM	B
23-Rosedale Road South	CR #43	Guthrie Road	2.7 9	02300 0	600	80	4	MON	B
23-Rosedale Road South	Guthrie Road	Roger Stevens Drive (CR 4)	3.0 6	02302 8	600	60/8 0	4	MON	B
24-Peneshula Road	Snye Road	Bellamy Road	3.0 9	02400 0	800	60	4	LH / MM	C
24-Bellamy Road	Peneshula Road	4th Con. Pakenham	3.3 6	02403 1	900	80	4	MM	C

ISSUED BY:

DATE ISSUED:

SUPERCEDES:

PAGE:

County Council

June 12, 2024

November 13, 2019

18 of 25

SUBJECT: Access to County Roads Policy

24-4th Con. Pakenham	Bellamy Road	Campbell Side Road	1.1 8	02406 5	900	80	4	MM	C
24-Campbell Side Road	4th Con. Pakenham	Waba Road (CR 20)	2.9 1	02407 7	600	80	4	MM	B
29-McNeely Avenue	Hwy. #7	Lake Avenue	1.5 7	02900 0	1200 0	80	2	CP	E
29-McNeely Avenue	Lake Avenue	Town Line Rd. East (CR 29)	1.1 7	02901 6	1400 0	60	3	CP	E
29-Town Line Road East	McNeely Avenue	Ramsay Con. 8	0.2	02902 8	9000	50	3	CP	E
29-County Rd. #29 South	Ramsay Con. 8	Wilson Street (CR 11)	1.8 9	02903 0	8000	80	2	MM	E
29-County Rd. #29 South	Wilson Street (CR 11)	Perth Street (CR 16A)	7.3 5	02904 9	7000	80	2	MM	E
29-Christian Street	Perth Street (CR 16A)	Almonte Street (CR 16)	0.6 1	02912 3	5000	70	3	MM	D
29-Christian Street	Almonte Street (CR 16)	Gleeson Road	0.7 2	02912 9	5000	70	3	MM	D
29-County Rd. #29 North	Gleeson Road	Snedden Road	6.3 2	02913 6	3700	80	3	MM	D
29-County Rd. #29 North	Snedden Road	McWatty Road	7.4 7	02920 0	3700	80	3	MM	D
29-County Rd. #29 North	McWatty Road	Waba Road (CR 20)	0.8 1	02927 5	4000	50	4	MM	D
29-County Rd. #29 North	Waba Road (CR 20)	Kinburn Sideroad (CR 20)	0.3 7	02928 3	4000	50	4	MM	D
29-County Rd. #29 North	Kinburn Sideroad (CR 20)	Walter Bradley Road	3.6 3	02928 7	2800	80	3	MM	C
29-County Rd. #29 North	Walter Bradley Road	Lanark County Sign (Ottawa Bndry)	2.4 5	02932 4	2800	80	3	MM/OTW	C
36-Bolingbroke Road	Leeds Bndry	Althorpe Road (CR 6)	0.7 1	03600 0	800	80	4	TVT	C
36-Bolingbroke Road	Althorpe Road (CR 6)	Hanna Road	5.6 5	03600 8	800	80	4	TVT	C
36-Bolingbroke Road	Hanna Road	Maberly Station Road	7.6 6	03606 5	500	80	4	TVT	B
36-Bolingbroke Road	Maberly Station Road	Hwy. #7	0.6	03614 0	800	60	4	TVT	C
36-Maberly Elphin Road	Hwy. #7	PIN #400 (Maberly)	1.5 8	03614 8	600	60	4	TVT	B
36-Maberly Elphin Road	PIN #400 (Maberly)	Bennett Lake Rd. (CR 19)	2.5 2	03615 9	800	80	4	TVT	C
36-Maberly Elphin Road	Bennett Lake Rd. (CR 19)	LDNS Sign (Twp Bndry)	2.9 3	03618 9	600	80	4	TVT	B
36-Elphin Maberly Road	LDNS Sign (Twp Bndry)	Elphin Hamlet Sign West	6.3 4	03621 7	600	80	4	LH	B
36-Elphin Maberly Road	Elphin Hamlet Sign West	CR 12 (McDonalds Corners Rd)	0.5 3	03628 0	600	60	4	LH	B
36-Elphin Maberly Road	CR 12 (McDonalds Corners Rd)	Elphin Hamlet Sign North	0.3 7	03628 7	500	60	4	LH	B
36-Elphin Maberly Road	Elphin Hamlet Sign North	PIN #3923 (Frontenac Bndry)	4.3 8	03629 1	500	60/8 0	4	LH	B
43-Hwy 43	Merrickville Bndry (West)	Rosedale Rd. S (CR 23)	8.4 9	04300 0	3600	80	3	MON	D
43-Hwy 43	Rosedale Rd. S (CR 23)	New Smiths Falls Boundary	4.8	04308 6	4800	80	3	MON	D
43-Hwy 43	Mazie Street (SFalls Bndry)	Station Road	7.6 5	04314 4	9000	80	2	DNE	E
43-Hwy 43	Station Road	Port Elmsley Rd. (CR 18)	0.2 5	04322 1	7000	60	3	DNE	E
43-Hwy 43	Port Elmsley Rd. (CR 18)	Meadow Lane	1.1 7	04322 4	8500	60	3	DNE	E
43-Hwy 43	Meadow Lane	Irwin Street	8.3 4	04330 6	7000	80	3	DNE/P	E
49-March Road	Ottawa Bndry	Appleton Side Rd. (CR 17)	2.9	04900 0	7500	80	2	MM	E
511-Lanark Road	Hwy. #7	PIN #40 (Perth Bndry)	0.7 1	51100 0	8000	60	3	TVT/P	E
511-Hwy 511	PIN #40 (Perth Bndry)	Clarchris Road	0.6	51100	8000	70	3	TVT/DNE	E

ISSUED BY:

DATE ISSUED:

SUPERCEDES:

PAGE:

County Council

June 12, 2024

November 13, 2019

19 of 25

SUBJECT: Access to County Roads Policy

			9	7					
511-Hwy 511	Clarchris Road	PIN #1325 (Balderson South)	5.04	511014	8000	80	2	TVT/DNE	E
511-Hwy 511	PIN #1325 (Balderson South)	Fallbrook Road (CR 7)	0.39	511067	8000	60	3	TVT/DNE	E
511-Hwy 511	Fallbrook Road (CR 7)	Township Bndry Road	0.32	511069	4000	60	3	TVT/DNE	D
511-Hwy 511	Township Bndry Road	Fergusons Falls Rd.(CR 15)	6.51	511072	4000	80	3	DNE	D
511-Hwy 511	Fergusons Falls Rd.(CR 15)	Toll Road	0.44	511138	4000	60	3	DNE	D
511-Hwy 511	Toll Road	South Street (CR 12)	0.62	511143	4000	50	3	LH	D
511-South Street	South Street (CR 12)	George Street	0.08	511149	4000	50	4	LH	D
511-George Street	Mill Street (CR 12)	Robertson Drive (South)	1.11	511150	4000	50	3	LH	D
511-Hwy 511	Robertson Drive (South)	Robertson Drive (North)	1.08	511160	2200	80	3	LH	C
511-Hwy 511	Robertson Drive (North)	Herron Mills Rd. (CR 8)	2.8	511171	2200	80	3	LH	C
511-Hwy 511	Herron Mills Rd. (CR 8)	Watsons Corners Rd.(CR 8)	0.73	511202	2200	80	3	LH	C
511-Hwy 511	Watsons Corners Rd.(CR 8)	PIN #5319 (Hopetown South)	3.37	511209	2200	80	3	LH	C
511-Hwy 511	PIN #5319 (Hopetown South)	Wolf Grove Rd. (CR 16)	0.76	511248	2200	60	4	LH	C
511-Hwy 511	Wolf Grove Rd. (CR 16)	PIN #5633 (Hopetown North)	0.77	511251	2100	60	4	LH	C
511-Hwy 511	PIN #5633 (Hopetown North)	South Lavant Rd. (CR 16)	1.24	511257	2100	80	3	LH	C
511-Hwy 511	South Lavant Rd. (CR 16)	McIlraith Road (CR 9A)	6.49	511272	1200	80	3	LH	C
511-Hwy 511	McIlraith Road (CR 9A)	Tatlock Road (CR 9)	2.68	511335	500	80	4	LH	B
511-Hwy 511	Tatlock Road (CR 9)	Radley Lane	3.92	511362	500	80	4	LH	B
511-Hwy 511	Radley Lane	White Lake Road	8.68	511402	500	80	4	LH	B
511-Lanark Road	White Lake Road	Renfrew Bndry	0.58	511489	500	80	4	LH	B

ISSUED BY:

County Council

DATE ISSUED:

June 12, 2024

SUPERCEDES:

November 13, 2019

PAGE:

20 of 25

SUBJECT: Access to County Roads Policy

SCHEDULE C: ENTRANCE CONFIGURATION

**RURAL ENTRANCES
TO COUNTY ROADS ON FILL**

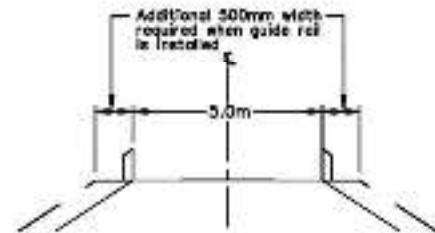
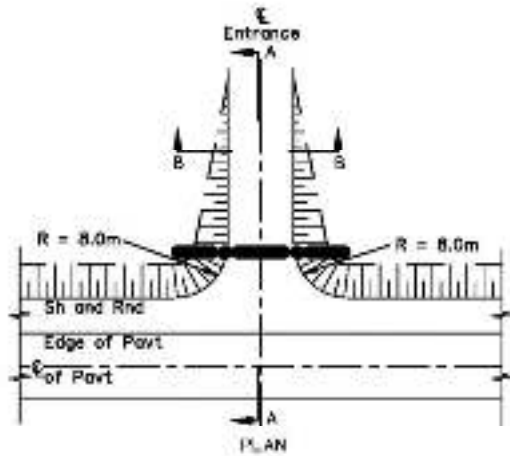

SECTION B - B

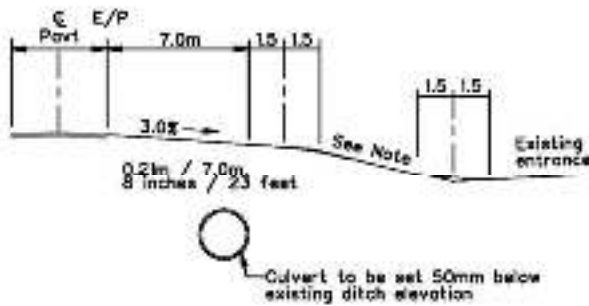

SECTION A - A

NOTES:

- A. DESIRABLE ENTRANCE CONFIGURATION, WHEN CONSTRAINTS PERMIT, DESIRABLE MAXIMUM GRADIENT: 8% FOR RESIDENTIAL ENTRANCES AND 10% FOR FARM AND FIELD ENTRANCES.
- B. ALL DIMENSIONS ARE IN MILLIMETRES OR METRES UNLESS OTHERWISE SHOWN.

**RURAL ENTRANCES
ON FILL
COUNTY OF LANARK
OCT 2019**

ISSUED BY:

County Council

DATE ISSUED:

June 12, 2024

SUPERCEDES:

November 13, 2019

PAGE:

21 of 25

SUBJECT: Access to County Roads Policy

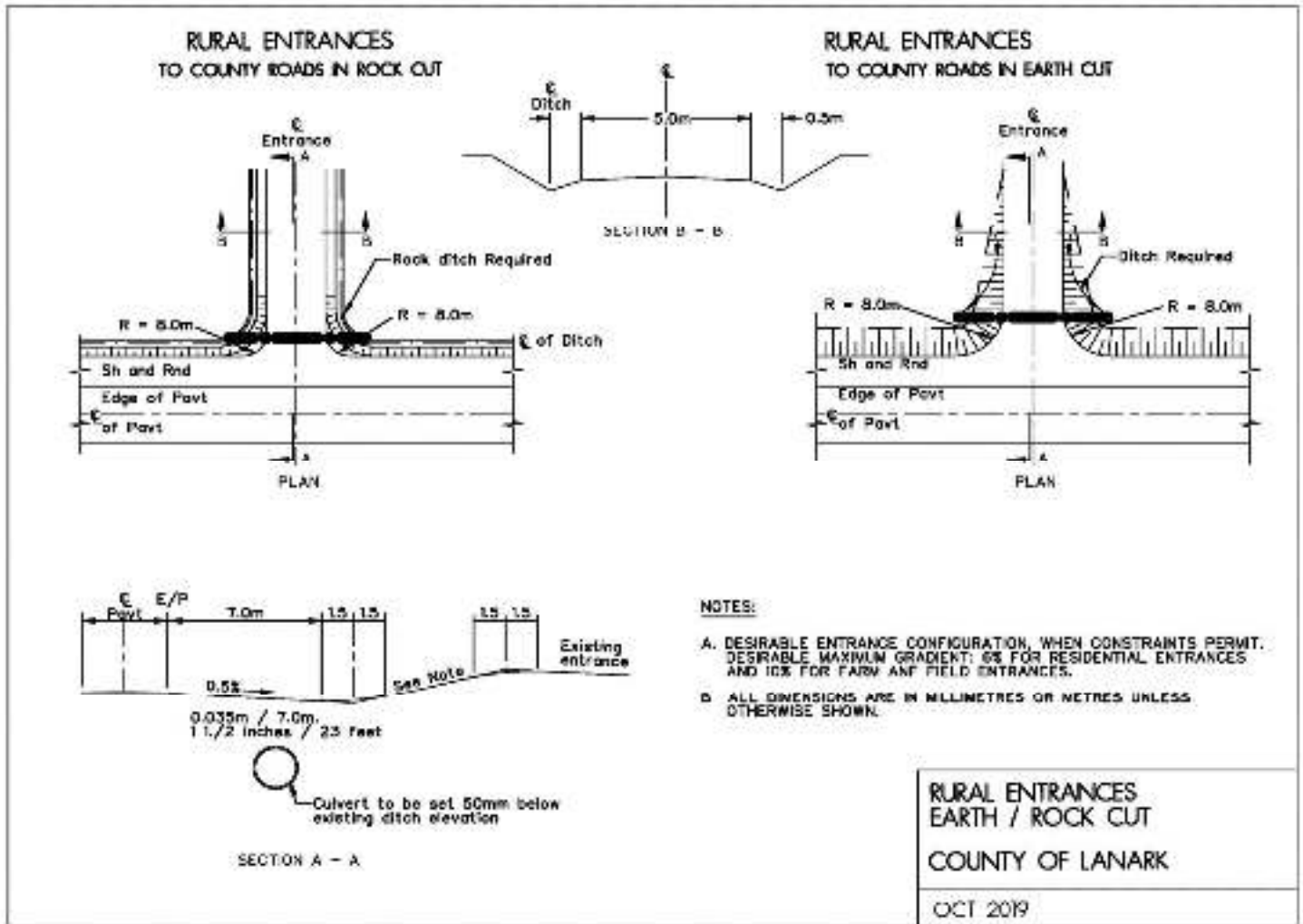

ISSUED BY:

County Council

DATE ISSUED:

June 12, 2024

SUPERCEDES:

November 13, 2019

PAGE:

22 of 25

SUBJECT: Access to County Roads Policy

COMMERCIAL, COMMON RESIDENTIAL OR FARM/ FIELD ENTRANCES TO COUNTY ROADS ON FILL

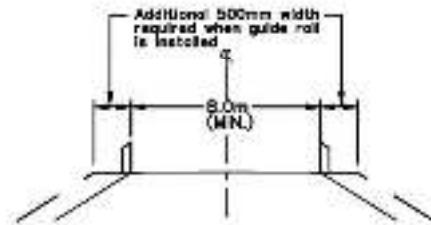
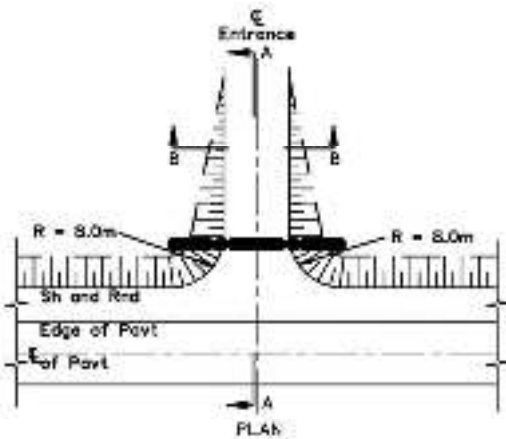

SECTION B - B

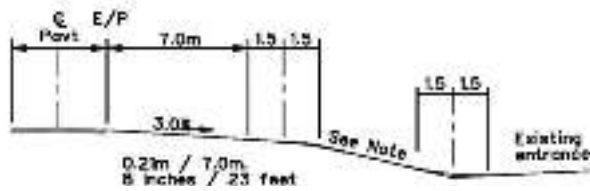

SECTION A - A

NOTES:

- A. DESIRABLE ENTRANCE CONFIGURATION WHEN CONSTRAINTS PERMIT. DESIRABLE MAXIMUM GRADIENT: 6% FOR RESIDENTIAL ENTRANCES AND 10% FOR FARM AND FIELD ENTRANCES.
- B. ALL DIMENSIONS ARE IN MILLIMETRES OR METRES UNLESS OTHERWISE SHOWN.

COMMERCIAL, COMMON RESIDENTIAL OR FARM/ FIELD ENTRANCES ON FILL
COUNTY OF LANARK

OCT 2019

ISSUED BY:

County Council

DATE ISSUED:

June 12, 2024

SUPERCEDES:

November 13, 2019

PAGE:

23 of 25

SUBJECT: Access to County Roads Policy

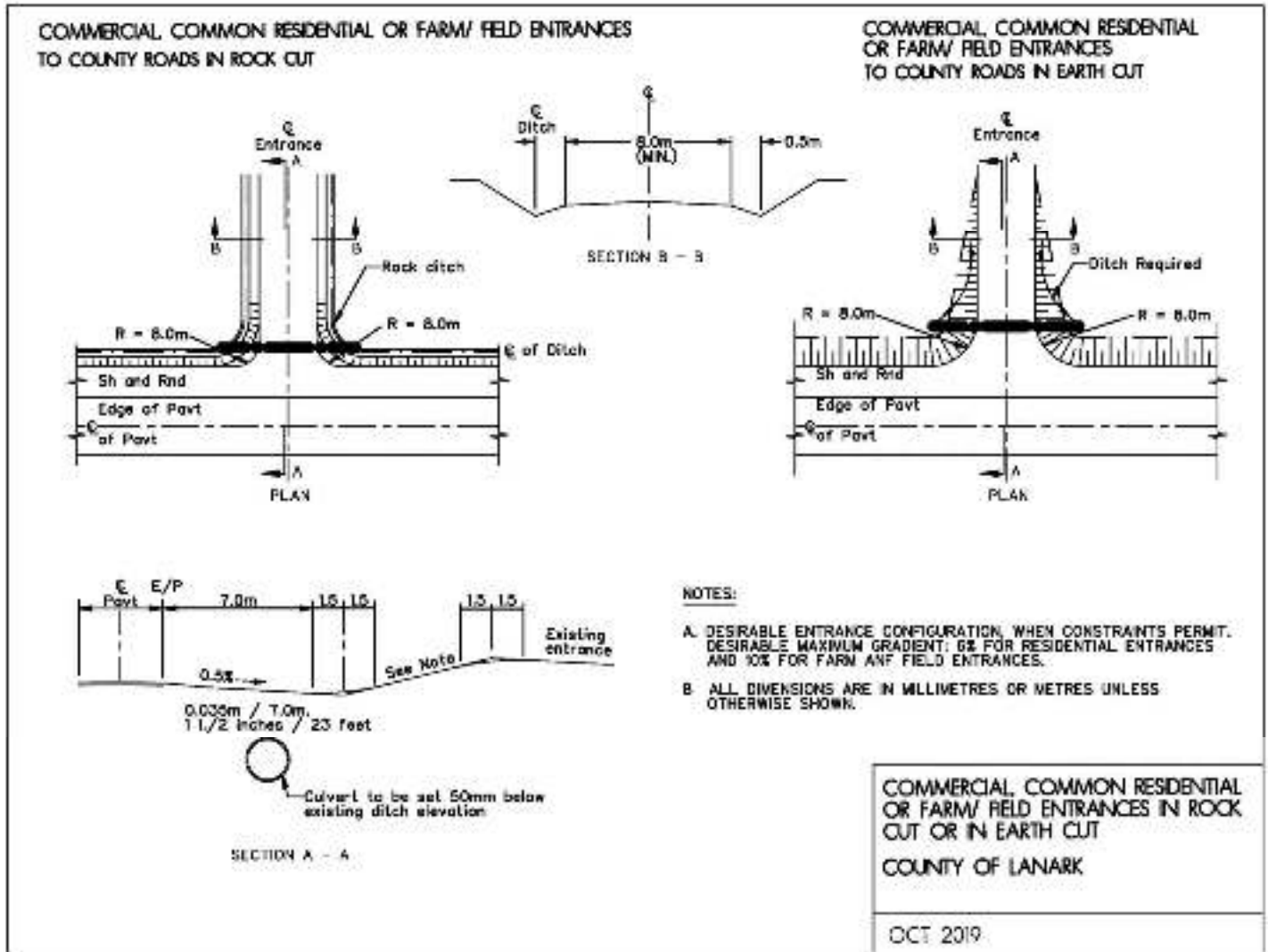

ISSUED BY:

County Council

DATE ISSUED:

June 12, 2024

SUPERCEDES:

November 13, 2019

PAGE:

24 of 25

SUBJECT: Access to County Roads Policy

SCHEDULE D: FEES

Application	Fee
Alter Existing Entrance (Note 1)	\$100
Entrance Inquiry (Note 3)	\$100
Entrance: Farm, Field, Residential, Temporary, Shared, Other. Non-Severance Related Severance Relates	\$200 \$250
Multi-Residential	\$350
Commercial/Industrial/Institutional, Private/ Public Road	\$500
Additional Inspections (Note 2)	\$75

NOTES:

1. An application to alter an existing entrance, without changing the type of entrance, must be submitted before:
 - i) Paving an existing gravel entrance
 - ii) Replacing an existing entrance culvert
 - iii). Adding an extension to an existing entrance culvert
 - iv). Widening an existing entrance
2. The non-refundable application fees include all costs associated with the processing of the application, including up to three (2) visits to the site, if necessary, by Public Works Department staff. An additional \$75 fee will be charged for each additional site visit that is required as a result of changes to the application by the applicant. The additional fee shall be payable before the additional site visit is scheduled.
3. This Entrance Inquiry fee will be deducted from the Entrance Application fee, if the full application is submitted within one year of the Inquiry Fee.

ISSUED BY:

County Council

DATE ISSUED:

June 12, 2024

SUPERCEDES:

November 13, 2019

PAGE:

25 of 25